

Operating guide

APP pumps

APP 1.5 - 3.5

Installation, Operation and Maintenance Manual



Table of Contents

Contents

Table of Contents	2
Validity	4
1. Introduction	5
1.1 General	5
1.2 Symbols	5
1.3 Manufacturer and customer service address	6
1.4 Country specific information	6
1.4.1 United Kingdom	6
2. Safety	6
2.1 General information	6
2.2 Preferred system design	6
2.3 Commissioning and servicing the unit	7
2.4 Adhere to the following important points	7
2.5 In case of doubt	7
3. Technical data	7
3.1 Approved applications and operational limits for the pumps	7
3.2 Application range	7
3.3 Electric motor data	7
3.4 Noise and vibration	7
3.5 Dimension drawings	7
3.6 Space requirement	7
3.7 Filtration	8
3.8 Properties of water	8
3.9 Air bubbles	8
3.10 Chemicals	8
4. Arrival inspection, transportation, handling, lifting and storage	8
4.1 Arrival inspection	8
4.2 Warning	8
4.3 General safety information	8
4.4 Transport and handling	8
4.5 Return to supplier	9
4.6 Storage	9
5. Installation and commissioning	10
5.1 Important dimensions	10
5.2 Cleanliness	10
5.3 Fluid temperature	10
5.4 Electrical data	10
5.5 Local regulations	10
5.6 Pre mounting checklist, based on Danfoss preferred system design	11
5.7 Lifting and positioning	11
5.8 Mount the different equipment	11
5.9 Electrics	11
5.10 Instrumentation	11
5.11 Connections	11
5.12 Ensure free flow	12
5.13 Verify setting of safety/relief valves	12
5.14 Flush the pump	12
5.15 Bleed and remove air from the pump	12
5.16 Verify direction of rotation	12
5.17 Commissioning	12
5.18 Check the filter condition	12
5.19 Instruct operator and maintenance personnel	12
6. Operation of pump unit	13
6.1 General safety information	13
6.2 What to listen and look for	13

7.	Maintenance and service of the pump unit	13
7.1	General safety information	13
7.2	Service and inspection interval for the pump	13
7.3	Shut down of the system	13
7.4	Disassembling and assembling the pump unit	14
7.5	Assembling the pump unit	14
7.6	Procedure for mounting the pump onto the electric motor	14
7.7	Getting the pump unit back into operation	14
7.8	Storage of the pump	14
8.	Troubleshooting and scrapping criteria	15
8.1	General safety information	15
8.2	Operational conditions which can cause pump failures	15
8.3	Mechanical failure	15
8.4	Electrical failure	15
8.5	Responsibility	15
8.6	Scrapping criteria	15
	Appendices	17
	Table of Contents	18
1.	Data sheet for APP 1.5-3.5 (AI274333290009en-000701)	19
2.	Pump instruction APP 1.5-3.5 (180R9065)	33
3.	IOM Electric motors (180R9230)	41
4.	Recommended service intervals for APP pumps (AX290239527130en-000201)	47
5.	Parts list for APP 1.5-3.5 (AX274346749037en-000501)	51
6.	Trouble shooting guide for APP, APP S and APP S 674 pumps	61
7.	Right and wrong (180R9042)	73

Operating guide | APP 1.5-3.5 pumps

Validity

This manual is valid for APP pumps both non ATEX and ATEX certified versions. An ATEX certified pumps are indicated by Ex in the designation - example APP 3.5 Ex.

In case the pump delivered is ATEX certified, the additional ATEX instruction must also be read.

APP 1.5	Code no.	180B3043	APP 1.5 Ex	On request
	Serial no.	XXXXXX02-XXX		XXXXXX02-XXX
APP 1.8	Code no.	180B3044	APP 1.8 Ex	On request
	Serial no.	XXXXXX02-XXX		XXXXXX02-XXX
APP 2.2	Code no.	180B3045	APP 2.2 Ex	180B3145
	Serial no.	XXXXXX02-XXX		XXXXXX02-XXX
APP 2.5	Code no.	180B3046	APP 2.5 Ex	180B3146
	Serial no.	XXXXXX02-XXX		XXXXXX02-XXX
APP 3.0	Code no.	180B3030	APP 3.0 Ex	180B3130
	Serial no.	XXXXXX02-XXX		XXXXXX02-XXX
APP 3.5	Code no.	180B3032	APP 3.5 Ex	180B3132
	Serial no.	XXXXXX02-XXX		XXXXXX02-XXX



The serial number is referring to the Serial no. on the product label. The digits shown (03) indicate the version number of the pump. This documentation is compatible with previous pump versions.

1. Introduction

1.1 General

The APP pumps and pump units are manufactured by Danfoss A/S, and are sold and marketed by a net of authorized distributors world wide.

This manual contains the necessary instructions for the installation, operation and service of the pumps used in a Sea Water Reverse Osmosis (SWRO) system or Brackish Water Reverse Osmosis (BWRO) system.

In case the pump delivered is ATEX certified, the additional ATEX instruction must also be read.

The APP pumps must not be used for other purposes than those recommended and specified without first consulting your local pump distributor.



Use of the pump in other applications that are not suitable for the pump unit can cause damages to the pump unit, with risk of personal injury.



All personnel being responsible for operation and maintenance of the pump unit must read and fully understand these instructions, especially the section "Safety", before:

- Transportation of the pump unit
- Lifting the unit
- Installing the pump unit
- Connecting the pump unit to the water system
- Connecting the electric motor and instrumentation
- Commissioning the unit
- Servicing the pump unit, mechanical and electrical parts
- Decommissioning the pump unit

The pump must always be installed and used in accordance with existing national/local sanitary, safety regulations and laws.

It is the responsibility of the safety officer or the chief operator to assure compliance with all local regulations that are not taken into account in this manual.



Changing the pumps' or pump units' operational limits and hardware:

- Changes to the delivered pump or motor pump unit may only be done with a written approval from Danfoss High Pressure Pumps.
- Operation outside the Danfoss specifications requires a written approval from Danfoss High Pressure Pumps.

- If any changes are made without written approval the warranty will automatically become void.

It is important that these instructions are always available to the personnel concerned.

If the recommendations in the manual are not followed, Danfoss reserves the right to void the warranty.

1.2 Symbols



Indicates something to be noted by the reader



Indicates a situation which will or could result in damage to the pump and its function



Indicates a situation which will or could result in personal injury and/or damage to the pump



Electrical hazard - Indicates a high-voltage warning



Safety glasses required



Hearing protection required



Safety shoes required



Safety helmet required



Protective garments must be worn

Protective garments must be worn



Danger Hot
Do not touch

Danger HOT.
Do not touch

1.3 Manufacturer and customer service address

**Danfoss A/S
Danfoss High Pressure Pumps**

Nordborgvej 81,
DK-6430 Nordborg
Denmark

Telephone: +45 7488 4024
Fax: +45 7445 3831
Email: highpressurepumps@danfoss.com
Homepage: hpp.danfoss.com

Your local Danfoss pump distributor can be found on our homepage.

Data sheets and instructions on all accessories are available on hpp.danfoss.com

1.4 Country specific information

1.4.1 United Kingdom

UK importer:

Danfoss Ltd.
22 Wycombe End
HP9 1NB Beaconsfield
United Kingdom

2. Safety



2.1 General information

Dangers that can arise from not following the instructions:

When the pump or pump unit is managed by untrained personnel, there is a danger of:

- Death or fatal injuries
- Costly damages and claims



All electrical installation work must only be carried out by authorized personnel in accordance with EN60204-1 and/or local regulations.

It is recommended to install a lockable circuit breaker to avoid inadvertent starting and/or electrical hazard. The lockable circuit breaker must be used during installation, operation and maintenance.

It is recommended to place a local safety switch nearby the pump, enabling service personnel to cut power for the electric motor.

Protect the motor and other electrical equipment from overloads with suitable equipment.

In case the pump delivered is ATEX certified, the additional ATEX instruction must also be read.



Always wear suitable safety clothing when handling the pump.

When working near the pump system, safety shoes, safety glasses, hearing protection and safety helmet must always be worn.



Under certain operational conditions the surface of the pump can be above 60°C / 140°F. Under these conditions the pump must be labelled with a "Danger Hot" sign.

When using an electric motor, the motor must always be supplied with adequate cooling ventilation.

When using an electric motor together with a VFD, the motor must be designed for operation with a VFD.

VFD operation may increase the temperature inside the electric motor if the motor is not designed for VFD operation. This can damage the motor and cause unintended breakdown.



Before start-up, the settings for all protective devices, such as sensors/switches and safety valves must be verified and free flow from safety valves must be ensured.



All pipe and hose connections must be stress-free mounted, securely fastened to the pump and well supported. Improper installation will or can result in personal injury and/or damage to the pump.

Use of this manual does not relieve operation and maintenance personnel of the responsibility of applying good judgment when operating and maintaining the pump and its components.

2.2 Preferred system design

Danfoss recommends to build systems with a high degree of safety. Danfoss preferred system design and P&ID are found in appendix 1, Data sheet, and appendix 2, Instruction.



It is always the system builder's responsibility that the system design does not cause any kind of hazard and is adapted to local regulations and standards.

Proper installation, proper start up and shut-down devices as well as high-pressure protection equipment is essential.

2.3 Commissioning and servicing the unit

It is recommended that commissioning and servicing are carried out by a minimum of two people, where one is acting as a supervisor.

2.4 Adhere to the following important points

- Before using the pump/pump unit it is very important to read and understand this user manual.

- Do not try to lift the pump unit manually; most of the pumps weigh more than 20 kilos, see specific weight for the pump in the appendix 1, Data sheet.
- Always bleed the pump prior to initial start-up.
- Do not mount the pump without the bell housing and a flexible coupling.
- Do not try to start the unit before the system components are mounted, bled and adjusted.
- Flush the system thoroughly before connecting the pump or pump unit.
- Check rotation direction of the motor before mounting the pump.

2.5 In case of doubt

Please contact Danfoss A/S in case of doubt. Contact information is listed in section 1.3, Manufacturer and customer service address.

3. Technical data



3.2 Application range

See appendix 1, Data sheet.

3.3 Electric motor data

See recommended motor in appendix 1, Data sheet or appendix 3, IOM for motors. The motors mentioned are the most common used motors by Danfoss High Pressure Pumps.

3.4 Noise and vibration

Noise level for a pump unit with a "standard" motor measured according to EN ISO 3744: 2010, see appendix 1, Data sheet. Possibilities to reduce noise and vibration are described in the same Data sheet.

3.5 Dimension drawings

Dimensions of the different pumps can be found in appendix 1, Data sheet.

3.6 Space requirement

When doing service or replacing the complete pump unit, it is recommended to have sufficient space available around the pump in order to ensure easy access. Sufficient space means at least 1 meter/40 inches around the pump. When working with high pressures, it is important to have the right space available around the pump as stated in the safety requirements.



3.1 Approved applications and operational limits for the pumps

The pump and the pump units are designed for the use in a Sea Water Reverse Osmosis (SWRO) or Brackish Water Reverse Osmosis (BWRO) systems and Brackish Water Reverse Osmosis (BWRO) system.

The APP pumps must not be used for other purposes than those recommended and specified without first consulting your local pump distributor.



Use of the pump in other applications not suitable for the pump unit can cause damages to the pump unit, with risk of personal injury.

For system integration of the pump, please see appendix 1, Data sheet and appendix 2, Instruction.



3.7 Filtration

(10µm absolute [$\beta_{10} \geq 5000$])
Requirements are specified in appendix 1, Data sheet and in appendix 2, Instruction.

Danfoss recommends not to build a filter bypass function or to use filters with an integrated bypass. If the above recommendation is not followed the warranty for the pump will automatically become void.

It should be possible to monitor the condition of the filter via the differential/delta pressure across the filter.

Using insufficient filtration or a filter bypass can cause a failure or decreased service life of the pump.

3.8 Properties of water

It is recommended NOT to use the pumps in feed water concentrations higher than 50,000 ppm TDS without consulting your local Danfoss pump distributor.



3.9 Air bubbles

Large bubbles in a pressurised RO system can result in damage to piping, equipment and the pump.

All air must be bled from both the low-pressure and high-pressure side before the RO system is pressurised. Special consideration should be given in order to minimize air bubbles in the feed flow. Air bubbles can cause cavitation.



3.10 Chemicals

The pump should not be exposed to any chemicals as it can result in damage to piping, equipment and internal parts in the pump.

4. Arrival inspection, transportation, handling, lifting and storage

4.1 Arrival inspection

The pump is packed in a cardboard or wood box with plugs in the port connections to protect the pumps from damage during transportation.

When the shipment has arrived it is important to check the pump for any damages. The name plate/type designation must be in accordance with the delivery note and your order.

In case of damage and/or missing parts, a report should be documented and presented to the carrier at once.



4.2 Warning

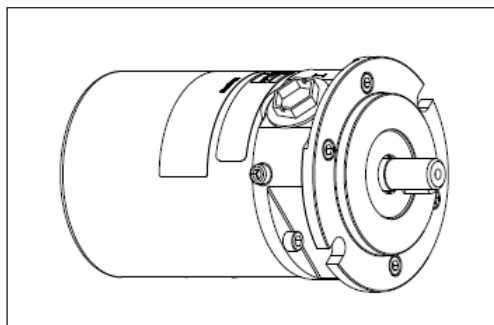
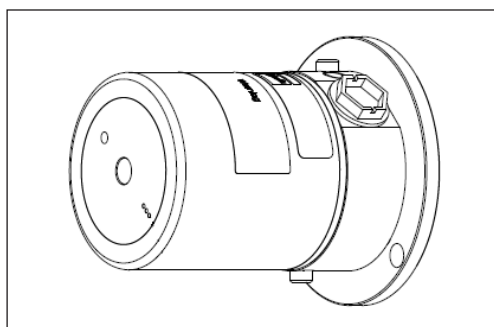
Before any lifting operation is performed, environmental conditions must be taken into consideration (Ex-rated areas, wind speed, wet/dry conditions, lifting height, etc.).

4.3 General safety information

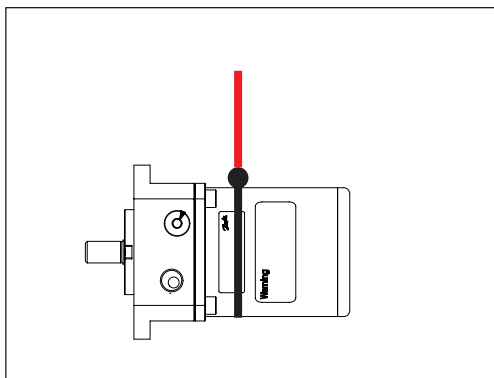
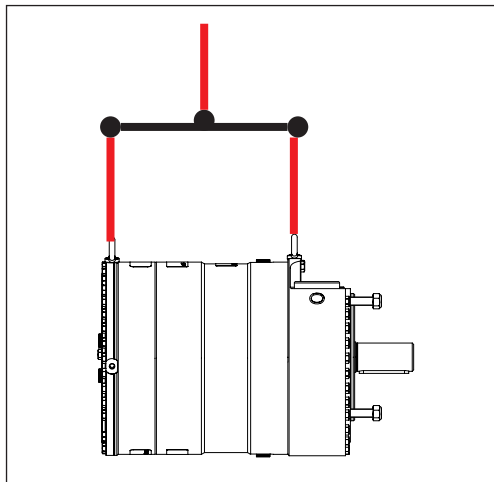
Personnel involved in lifting and transporting the equipment (see Safety, chapter 2) must be trained in handling and in safety procedures for lifting heavy loads. Many of the pumps and pump units weigh more than 20 kilos, which requires lifting slings and suitable lifting devices; e.g. an overhead crane or industrial truck to be used as minimum.

4.4 Transport and handling

Small pumps which have a weight below 20 kilos (weight can be found in appendix 1, Data sheet), can be handled by hand if they are not mounted together with an electric motor. The weight of a small pump with a motor will be above 20 kilos.



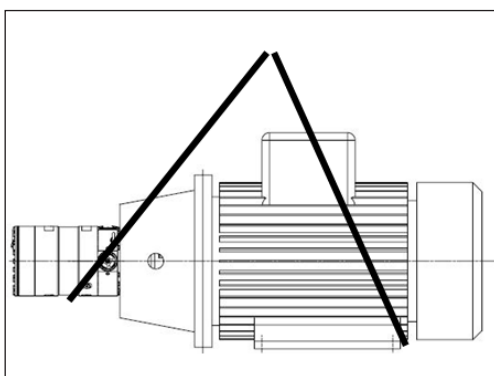
Pumps which have a weight above 20 kilos (see appendix 1, Data sheet) must be handled by using lifting eyes and slings.



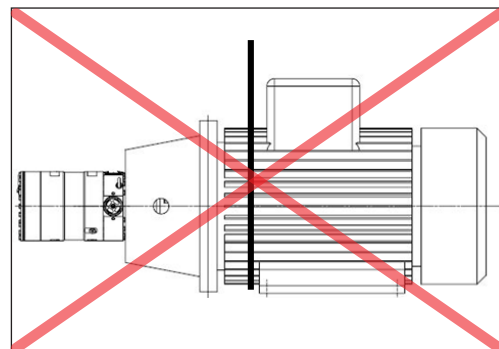
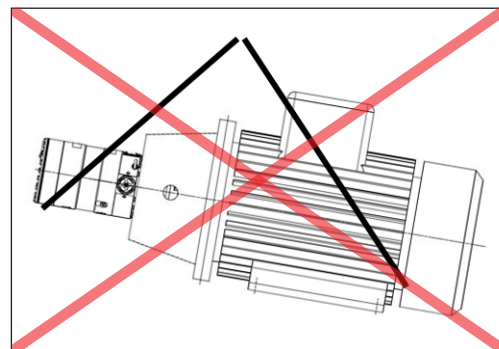
When the pump is mounted together with an electric motor, the pump unit always weigh more than 20 kilos and must be handled by using slings around the pump unit.

See below examples of where to/not to attach the lifting slings on the pump unit:

Correct lifting with 2 separate slings:



Wrong lifting:



When lifting the pump unit, one sling must be attached to the electric motor and one sling around the pump.

Some motors and pumps have specific lifting eyes.

**Do not use connections/nozzles for lifting!
Do not use only one sling!**

Make sure that the unit/load is balanced before lifting. The centre of the mass varies from pump/pump unit size to pump/pump unit.

How to mount the pump and the electric motor correctly, see appendix 1, Data sheet or appendix 2, Instruction.



Incorrect lifting can result in personal injury and/or damage to the pump unit, see appendix 2, Instruction.

4.5 Return to supplier

Please see maintenance chapter 7.

4.6 Storage

Each pump is tested before shipment, and will therefore contain water. For storage temperature and frost protection see appendix 2, Instruction.

The pumps are NOT delivered frost protected from the factory.

5. Installation and commissioning



5.1 Important dimensions

Physical dimensions and connections of the pump unit are described in appendix 1, Data sheet.



5.2 Cleanliness

It is very important that the tubes and pipes are **completely clean**: no dirt, chips or burrs are allowed. Flush all piping before connecting the high-pressure pump to ensure the system is clean. Internal surfaces of the piping must not be corroded. If dirt or rust is not removed, the pump and the valves can be damaged. In worst case the pump can be damaged beyond repair!



5.3 Fluid temperature

Before start-up, the fluid and pump housing temperature must be within the specified temperature range listed see appendix 1, Data sheet.

5.4 Electrical data

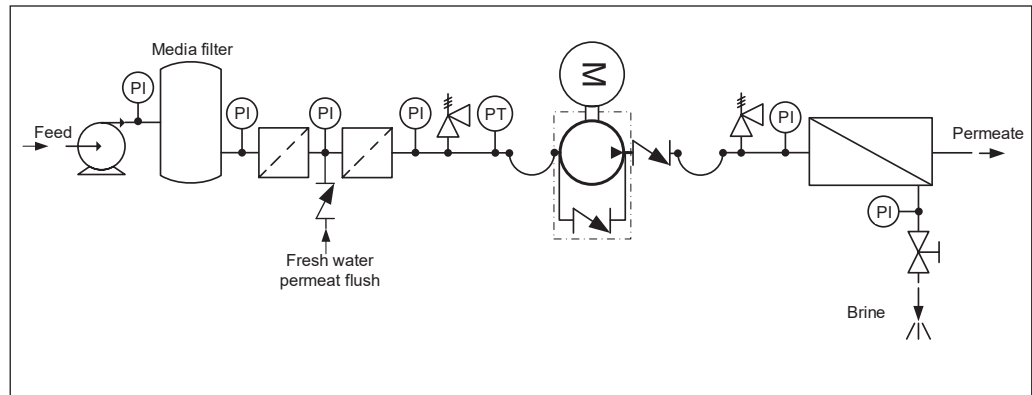
Check voltage, current frequency and rated power on the electric motor and VFD settings on the name plate placed on both the motor and the VFD.



5.5 Local regulations

Commissioning must always be done in accordance with valid regulations and local standards.

Schematic 1: Recommended system design



5.6 Pre mounting checklist, based on Danfoss preferred system design

Table 1: Check points when assembling and commissioning system

	Check points	Comment	OK ?
CP1	Ensure that the environmental conditions are safe.	See Arrival inspection, transportation, handling, lifting and storage, chapter 4.	
CP2	Minimum and maximum start-up temperature for fluid and pump.	See Data sheet or Instruction, appendices 1 and 2.	
CP3	Filtration condition (10 µm absolute ($\beta_{10} \geq 5000$))	See Danfoss requirements in Data sheet and Instruction, appendices 1 and 2	
CP4	Power supply for electric motor and VFD.	See Data sheet for the used motor and VFD.	
CP5	Safety circuit / breaker must be sized for the motor and environment (corrosion and humidity)	See Data sheet for the used safety circuit.	
CP6	Bolts and screws must conform to environmental conditions as well as fluid and torque requirements.		
CP7	Instrumentation, pressure switch should be designed to conform to the environment (corrosion and humidity).	See Data sheet for the used equipment.	
CP8	Check the factory settings of the safety/relief valves or pressure relief valves (page 11).	See Data sheets for the used valves.	
CP9	Check the settings of the pressure transmitter/switch (3) set at min. inlet pressure (page 11).	See Data sheet or Instruction, appendices 1 and 2.	
CP10	Check that all pressure indicators (PI) are selected to be able to measure the system pressure range (page 11).	Scaling should at least be 1 bar or more precise.	
CP11	Check coupling distance (air gab – movement of the spider)	3-5 mm	
CP12	Check correct connections on the pump (in & outlet)		
CP13	Check piping for possible air gaps.		



5.7 Lifting and positioning

Lift the pump unit onto base (Remember vibration dampeners, if needed). Fasten the motor to the base.

See also chapter 4, Arrival inspection, transportation, handling, lifting and storage.

5.8 Mount the different equipment

(connections, pipes, tubes, check and safety/relief valves, etc.)

- The hard piping and flexible hoses used, must be of proper design and must be installed in accordance with the manufacturer's recommendations. (see also Data sheet for Hose and hose fittings and Instruction for Assembling Hose kit - both available on www.ro-solutions.danfoss.com).
- Misalignment of the hard pipes may give unintended stress on the pump port connections and may damage the pump.
- Prevent excessive external pipe load.
- Do not connect piping by applying external force (use of wrenches, crane, etc.) Piping must be aligned without residual stress.
- Do not mount expansion joints so that their force applies internal pressure on the pump connections.

5.9 Electrics

All electrical installation work must be carried out by authorized personnel in accordance with EN60204-1 and/or local regulations (see also Safety, chapter 2).

Turn off the safety circuit breaker and lock it.

Mount the power cable on the electric motor.

If a VFD is used, adjust the protective motor switch/VFD to the current limits found on the name plate of the electric motor.

5.10 Instrumentation

The pressure switch/sensor should be mounted as close to the pump as possible. It is recommended to test the pressure/sensor switch via an instrumentation manifold.

Mount the pressure switch/sensors according to the manufacturer's instructions.

5.11 Connections

Mount and tighten connections and check valve(s) as specified.

5.12 Ensure free flow

Ensure free flow from the safety/relief valves 8 and 9 (schematic 1, page 11). A blocked safety/relief valve can cause excessive build-up of pressure and thereby cause dangerous situations and damage to the whole system.

5.13 Verify setting of safety/relief valves

Make sure, the safety/relief valves 8 and 9 are placed correctly.

Check the pressure settings on the name plates of the safety/relief valves. If they are within specifications, you can continue.

5.14 Flush the pump

Fully open the pressure valve at the brine outlet.

Close all the bleeding and draining plugs on the high-pressure pump.

Start the feed pump and ensure free flow to the high-pressure pump.

5.15 Bleed and remove air from the pump

Open the bleeding plugs. Keep the plugs open until the high-pressure pump is bled.

5.16 Verify direction of rotation

The direction of rotation must always follow the arrow. The arrow is placed on the pump or pump unit.

Check the direction of rotation before mounting the pump.

Unlock the safety circuit breaker. Start the motor for 1 second and observe the direction of rotation either looking at the fan of the motor or the coupling through the inspection hole in the bell housings (not available on all bell housings). If the motor is turning the wrong direction, switch two phases in the connection box of the motor or reprogram the direction in VFD.

When the motor is turning in the right direction, the pump can be mounted.

5.17 Commissioning

- Close all the bleeding and draining plugs.
- Open the pressure valve at the brine site.
- Switch the safety circuit breaker on for both motor(s) and VFD(s).
- Start the feed pump.
- Start the high-pressure pump.
- If a VFD or a soft starter is used, a ramp up time of minimum 10 seconds is required to avoid damage of the pump.
- Monitor the inlet and outlet pressure of the high-pressure pump and look for leakages.
- Check the function of the pressure indicators by slowly closing the valves. The pump unit should stop when the minimum inlet pressure and maximum outlet pressure has been reached.
- Adjust the pressures to the specified inlet and outlet pressure for the system and let the pump unit run until the electric motor and pump temperature is stable.
- If the system is running within the system design limits, the system is released for operation.


5.18 Check the filter condition

Evaluate contamination found in filter, replace filter elements, if necessary.


5.19 Instruct operator and maintenance personnel

Before using the pump/pump unit, the personnel must be instructed in using the pump/pump unit, its function, components, documentation and safety.

Danfoss offers commissioning and service at system manufacturer's location. Rate quotes are offered upon request.

6. Operation of pump unit

6.1 General safety information

Before inspecting the pump unit, read the Safety chapter 2 in this user manual.

6.2 What to listen and look for

If one or more of the following examples are observed, please act as indicated:

- A) Loose bolts – check all bolts and, if necessary, contact the maintenance department in order to have all bolts tightened to the specified torque(s).
- B) Leakage – if a small leakage from the bell housing is observed. Contact the maintenance department.
- C) Leakage – if there is a large leak, the unit should be stopped immediately. Contact the maintenance department.
- D) High frequency tones – safety/relief valves are either damaged or running very close to their design pressure, stop the unit immediately. Contact the maintenance department.
- E) Increased noise or vibration – requires the unit to be stopped immediately. Contact the maintenance department.
- F) Very high temperatures – may indicate that one or more parts are damaged inside the pump. The pump must be stopped immediately and inspected before it is restarted. Contact the maintenance department.

- G) Drop in flow and/or pressure – may indicate wear on one or more parts inside the pump. The pump must be stopped immediately and inspected before it is restarted. Contact the maintenance department.
- H) Other observations or troubles, please see appendix 7, Right and Wrong or appendix 6, the Trouble shooting guide. Both appendices give good advises regarding design, installation, wiring and troubleshooting. See also service and warranty section in appendix 1, Data sheet and appendix 2, Instruction.

If the pump is not stopped for inspection as recommended, it can lead to damage of the pump or break-down. See also service and warranty section in the appendix 1, Data sheet, in appendix 2, Instruction or appendix 4, Instruction for recommended service intervals.

Danfoss offers service of the pump at the system manufacturer's location as well as we offer training in how to service the pump. Quotes are offered upon request.

Danfoss recommends simultaneously to check the filter and membrane condition and to evaluate contamination; filter and membrane elements must be replaced if necessary.

7. Maintenance and service of the pump unit

7.1 General safety information

Before servicing the pump unit, it is necessary to read and understand this user manual, especially the Safety, chapter 2. Remember to wear suitable safety equipment according to Safety, chapter 2.

7.2 Service and inspection interval for the pump

Maintenance and service intervals are depending on the cleanliness level of the water, hydraulic load and temperature of the pump unit. The most important parameter is the filtration of the water.

See the section Service and warranty in the appendix 1, Data sheet, in appendix 2, Instruction and appendix 4, Instruction for recommended service intervals.

For spare parts and service tools, please see appendix 3, Parts list.

Danfoss offers service of the pump at the system manufacturer's location and training in how to service the pump. Quotes are offered upon request.

7.3 Shut down of the system

- A) Open the pressure valves at the brine site to release the pressure.
- B) Stop the high-pressure pump.
- C) Stop the feed pump.
- D) Switch off the safety circuit breaker for both the high-pressure pump, feed pump and VFD and lock them. Only personnel servicing the pump unit should be able to unlock/activate the switch again.
- E) Open bleeding and drain plugs. Wait until the pump and system are emptied for water.



- F) Slowly unscrew and remove the bolts and gaskets from the inlet/outlet hoses or pipes, be careful about jets of water. Beware that the system can be pressurized!
- G) Attach the lifting equipment to the pump unit. For instructions on lifting the complete pump unit, see chapter 4, Arrival inspection, transportation, handling, lifting and storage.
- H) For the small pumps, unscrew the bolts holding the pump to the bell housing. For the bigger pumps, unscrew the bolts/nuts from the pump and bell housing to the motor. Afterwards unscrew the bolts/nuts holding the pump and bell housing.
- I) Carefully pull the pump out of the bell housing by using lifting equipment, if necessary.
- J) Hold the pump in different positions above a drip tray; this should allow most of the water trapped in the pump to drain. Clean and dry the pump surface and plug the bleeding and draining plugs.
- K) Move the pump to a clean and safe location where the pump can be inspected/ serviced.

7.4 Disassembling and assembling the pump unit

- A) Remove all connections from the pump.
- B) Disassemble the pump according to the Disassembling and Assembling Instruction (available at www.ro-solutions.danfoss.com)

Clean all parts and surfaces with a fluid compatible with the materials found in the pump. Wipe the parts clean and dry with a lint-free clothing.
- C) Inspect all parts including shaft seal and if necessary, replace them; see appendix 3, Parts list.
- D) If the pump is going to be returned to Danfoss for repair or a warranty claim, it is important to contact Danfoss in order to receive a return number and a form to fill out with product information. A copy of the form together with contact information and reason for returning should be sent to the email address on the form. The same documents should be attached to the shipment.

Product information (see label on product) Only 1 product on each report.		
Product type	Code number	Serial number
Operational conditions		
Application	Inlet pressure	Rpm (pump/motor only)
Hours of operation	Outlet pressure	Number of duty cycles (valves only)
Filtration (µ, absolute/nominal)	Flow	Water temperature
Water type	TDS	Pumps in parallel (yes/no)

Returns without a return number will be rejected !!!

7.5 Assembling the pump unit

Assemble the pump according to the Disassembling and Assembling Instruction (available at www.ro-solutions.danfoss.com).

7.6 Procedure for mounting the pump onto the electric motor



Mount the flexible coupling and bell housing according to appendix 2, Instruction.

7.7 Getting the pump unit back into operation

Find instructions of how to put the pump unit back into operation in chapter 4, Arrival inspection, transportation, handling, lifting and storage and Installation and commissioning, chapter 5.

7.8 Storage of the pump

If the pump has to be shut down for a longer period, instructions can be found in appendix 2, Instruction.

8. Troubleshooting and scrapping criteria

8.1 General safety information

Before inspecting the pump unit, it is necessary to read and understand this user manual, especially the Safety chapter 2.

Remember to wear suitable safety equipment according to Safety chapter 2.

8.2 Operational conditions which can cause pump failures

The following conditions can cause a pump failure :

- The pump is running dry.
- The inlet pressure is too high.
- The inlet pressure is too low.
- The temperature of the fluid is too high.
- The ambient temperature is too high.
- The pump is running against a blocked port/closed manual valve.
- The pump is operating at a pressure out of specification.
- The pump is running with a non-specified/ approved fluid.
- The pump is running in the wrong direction.
- The filtration is insufficient.
- The pump is not being serviced according to Danfoss specifications (end of life).
- There is excessive mechanical load on the shaft coupling and piping.


8.3 Mechanical failure

If the pump is running dry, the temperature will quickly increase which can cause burns.

If there is any leakage at start-up or during operation, a high-pressure jet can cause eye or skin damage.

Leakage can result in flooding, which can cause slipping, tripping or falling.

If water is leaking into the electric motor; it can cause electric shock, fire, short circuit or even death. When mounting the pump vertically always mount the motor above the pump to avoid water leaking into the electric motor.


8.4 Electrical failure

If the wiring of the electric motor is incorrect or the ground connection is missing, it can cause electric shock, burn damages, fire or even death.

If a VFD is used and wrongly programmed, it can damage the pump and lead to high temperatures or other dangers.

All electrical installation must be carried out by authorized personnel in accordance with EN60204-1 and/or local regulations.

8.5 Responsibility

Danfoss takes no responsibility for any abnormal injuries, risks or damages that could arise caused by abnormal conditions, vibrations, corrosion, abrasives, foreign objects or excessive temperatures and shall not be liable for any consequential or incidental damages.

8.6 Scrapping criteria

Whether the pump can be repaired or need to be scrapped, depends on in which conditions the internal parts are, or how damaged the whole unit is. Please use appendix 6, Trouble shooting guide as guideline or send the pump to Danfoss headquarter in Denmark for evaluation.

For other observations or troubles, please see appendix 7, Right and Wrong which gives good advises regarding design, installation, wiring and troubleshooting.

In case the pump needs to be scrapped, please follow your local environmental rules.

Danfoss A/S
High Pressure Pumps
DK-6430 Nordborg
Denmark

Danfoss can accept no responsibility for possible errors in catalogues, brochures and other printed material. Danfoss reserves the right to alter its products without notice. This also applies to products already on order provided that such alterations can be made without subsequential changes being necessary in specifications already agreed. All trademarks in this material are property of the respective companies. Danfoss and the Danfoss logotype are trademarks of Danfoss A/S. All rights reserved.

Operating guide

Appendices

APP 1.5 - 3.5

Installation, Operation and Maintenance Manual



Table of Contents

Contents

Appendices17

1. Data sheet for APP 1.5-3.5 (AI274333290009en-000701)19

2. Pump instruction APP 1.5-3.5 (180R9065)33

3. IOM Electric motors (180R9230)..... 41

4. Recommended service intervals for APP pumps (AX290239527130en-000201)..... 47

5. Parts list for APP 1.5-3.5 (AX274346749037en-000501)51

6. Trouble shooting guide for APP, APP S and APP S 674 pumps61

7. Right and wrong (180R9042)73

Data sheet

APP Pumps

APP 0.6-1.0 / APP 1.5-3.5 /
APP (W) 5.1-10.2 / APP 11-13 /
APP 16-22 / APP 21-46



Table of Contents	1.	Introduction	21
	2.	Benefits.....	21
	3.	Application examples	21
	4	Technical data	22
	4.2	APP 1.5-3.5.....	22
	5.	Flow at different rpm.....	23
	5.2	APP 1.5-3.5 flow curves at 80 barg (1160 psig)	23
	6	Flushing valve curves	24
	6.2	APP 1.5-3.5 integrated flushing valve.....	24
	7.	Motor requirements.....	25
	7.2	Calculation factor for APP 1.5-3.5	25
	8.	Temperature and corrosion.....	26
	8.1	Temperature.....	26
9.	Installation.....	26	
9.1	Filtration.....	27	
9.2	RO system with direct supply:.....	27	
10.	Dimensions and connections.....	29	
10.2	APP 1.5-3.5.....	29	
11.	Dimensions with motor unit.....	30	
11.1	APP 0.6-3.5.....	30	
13.	Service.....	31	

Data sheet | APP 0.6-46 / APP (W) 5.1-10.2 pumps

1. Introduction

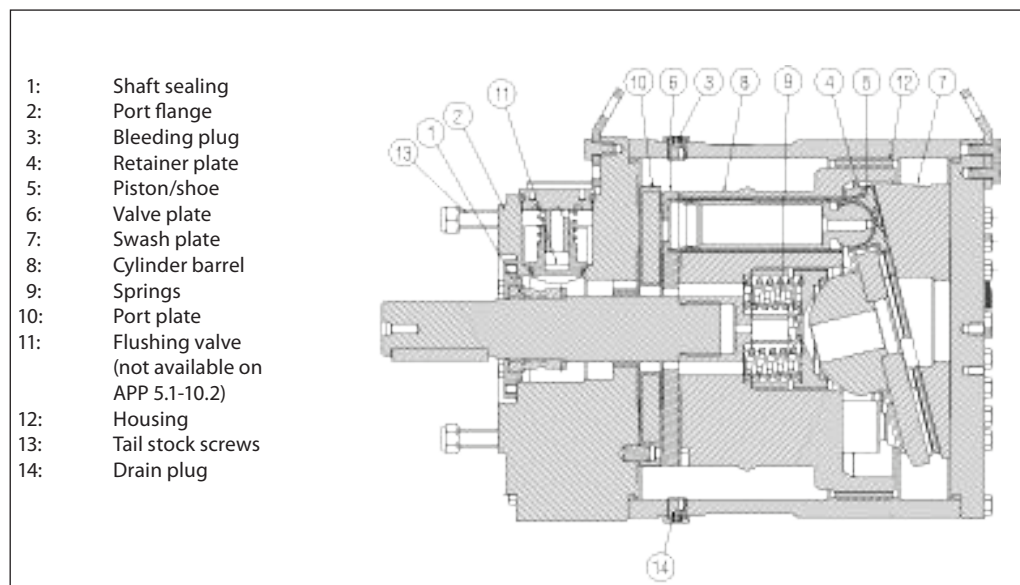
This data sheet is valid for APP pumps both non ATEX and ATEX certified. ATEX certified pumps are indicated by Ex in the type designation - example APP 0.6 Ex.

The Danfoss range of APP high-pressure pumps is designed according to EN 809 for use in RO applications with low viscosity and corrosive fluids such as:

- Sea water
- Brackish water
- Waste water (APP W)

Danfoss APP pumps are positive displacement pumps with axial pistons that move a fixed amount of water in each cycle. Flow is proportional to the number of input shaft revolutions (rpm). Unlike centrifugal pumps, they produce the same flow at a given speed no matter what the discharge pressure.

Below sectional drawing is an example of an APP pump. The sectional drawing for the specific pump sizes are to be found in the pump instruction.



2. Benefits

- **Zero risk of lubricant contamination:**
 - Oil lubricants are replaced with the pumped medium, water, so there is no contamination risk from the pump.
- **Low maintenance costs:**
 - Efficient design and all-stainless steel construction ensure exceptionally long life. When Danfoss specifications are met, service intervals of 8,000 hours can be expected. Service is easy, and can be carried out on-site due to the simple design and few parts.
- **Low energy costs:**
 - The highly efficient axial piston design provides the lowest energy consumption of any comparable pump on the market.
- **Easy installation:**
 - The most compact and lightest design available.
 - The pump can be installed vertically and horizontally.
 - No pulsation dampeners necessary due to extremely low pressure pulsation.
- **Powered directly by electric motors or combustion engines (with special coupling).**
- **All pumps except APP (W) 5.1 - 10.2 are supplied with an integrated flushing valve that allows the fluid to flow from inlet to the outlet, when the pump is not running.**
- **High reliability:**
 - All parts are made of high corrosion resistant materials e.g. Duplex (EN1.4462/ UNS S31803) and Super Duplex (EN1.4410/UNS S32750) stainless steel and carbon reinforced PEEK.
- **Certified quality:**
 - Pumps available as ATEX certified.
 - For other certifications, please see data sheets for APP S (all super duplex) and APP S 674 (API).
 - Positive Material Identification (PMI) report available on request.
 - IATF 16949, ISO 9001, ISO 14001.

3. Application examples

Danfoss APP pumps are built into a broad range of RO desalination plants around the world:

- Containerized solutions for hotels, resorts and residences on islands and in coastal regions
- Mobile systems for humanitarian and military organizations
- Onboard systems for ships and yachts
- Offshore platforms for the oil and gas industry
- Municipal and regional waterworks

4 Technical data
4.2 APP 1.5-3.5

Pump size		APP 1.5	APP 1.8	APP 2.2	APP 2.5	APP 3.0	APP 3.5
Code number APP		180B3043	180B3044	180B3045	180B3046	180B3030	180B3032
Code number APP ATEX ⁴⁾		180B3143	180B3144	180B3145	180B3146	180B3130	180B3132
Geometric displacement	cm ³ /rev.	9.31	10.04	12.52	15.35	17.70	20.54
	in ³ /rev.	0.57	0.61	0.76	0.94	1.08	1.25
Pressure							
Max. outlet ¹⁾ pressure continuous	barg	83	83	83	83	83	83
	psig	1200	1200	1200	1200	1200	1200
Min. outlet ¹⁾ pressure	barg	20	20	20	20	20	20
	psig	290	290	290	290	290	290
Inlet pressure continuous	barg	0.5 - 5 ²⁾	0.5 - 5 ²⁾	0.5 - 5 ²⁾	0.5 - 5	0.5 - 5 ²⁾	0.5 - 5
	psig	7.3 - 72.5 ²⁾	7.3 - 72.5 ²⁾	7.3 - 72.5 ²⁾	7.3 - 72.5	7.3 - 72.5 ²⁾	7.3 - 72.5
Max. inlet pressure peak	barg	10	10	10	10	10	10
	psig	145	145	145	145	145	145
Speed							
Min. speed continuous	rpm	700	700	700	700	700	700
Max. speed continuous	rpm	3450 ²⁾	3450 ²⁾	3450 ²⁾	3000	3450 ²⁾	3000
Typical flow - Flow curves available in item 5							
1000 rpm at max. pressure	m ³ /h	0.53	0.57	0.73	0.90	1.02	1.19
1500 rpm at max. pressure	m ³ /h	0.79	0.86	1.09	1.34	1.54	1.79
1200 rpm at max. pressure	gpm	2.80	3.03	3.83	4.73	5.41	6.30
1800 rpm at max. pressure	gpm	4.19	4.55	5.75	7.09	8.12	9.46
Technical specifications							
Media ³⁾ temperature	°C	2 - 50	2 - 50	2 - 50	2 - 50	2 - 50	2 - 50
	°F	36 - 122	36 - 122	36 - 122	36 - 122	36 - 122	36 - 122
Ambient temperature	°C	0 - 50	0 - 50	0 - 50	0 - 50	0 - 50	0 - 50
	°F	32 - 122	32 - 122	32 - 122	32 - 122	32 - 122	32 - 122
Weight (dry)	kg	8.6	8.6	8.6	8.6	8.6	8.6
	lb	17	17	17	17	17	17
Sound pressure level ⁵⁾	dB(A)	77	77	77	81	81	81
Footprint with IEC motor ⁶⁾	m ²	0.15	0.16	0.21	0.21	0.30	0.30
	foot ²	1.61	1.72	2.26	2.26	3.23	3.23
Typical motor size							
Max. speed at max. pressure	kW	5.5	5.5	7.5	7.5	11	11
3000 rpm at max. pressure	HP	7.5	7.5	10.0	15.0	15.0	15.0
Torque at max. outlet pressure	Nm	13.0	13.9	17.4	21.3	24.5	28.7
	lbf-ft	9.6	10.3	12.8	15.7	18.1	21.2

¹⁾ For lower and higher pressure, please contact Danfoss.

²⁾ For speeds above 3000 rpm the pump must be boosted at a pressure of 2-5 barg (29- 72.5 psig).

³⁾ Dependent on the NaCl concentration - see chapter 8.

⁴⁾ Category 2, Zone 1 or Category 3, Zone 2.

⁵⁾ A-weighted sound pressure level at 1 m from the pump unit surfaces (reference box) acc. to EN ISO 20361 section 6.2. The noise measurements are performed acc. to EN ISO 3744:2010 on a motor-pump unit at max. pressure and speed.

⁶⁾ Max. area covered with recommended motor configuration (excl. of space to service pump)

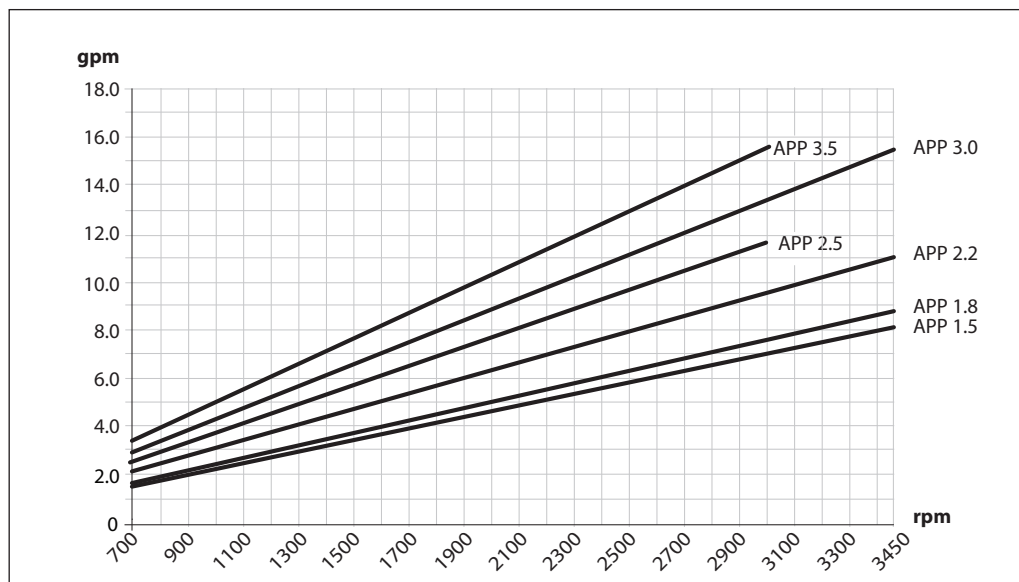
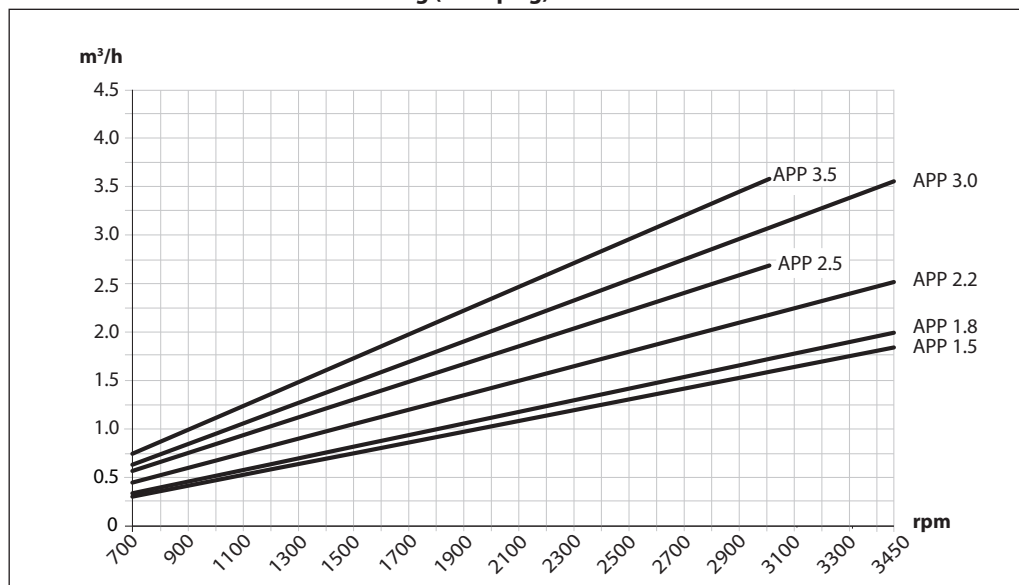
5. Flow at different rpm

If the flow required and the rotation speed (rpm) of the pump is known, it is easy to select the pump fitting the application best by using the diagrams below.

Furthermore, these diagrams shows that the flow can be changed by changing the rotation speed of the pump. The flow/rpm ratio is constant, and the "required" flow can be obtained by changing the rotation speed to a corresponding value. Thus, the required rpm can be determined as:

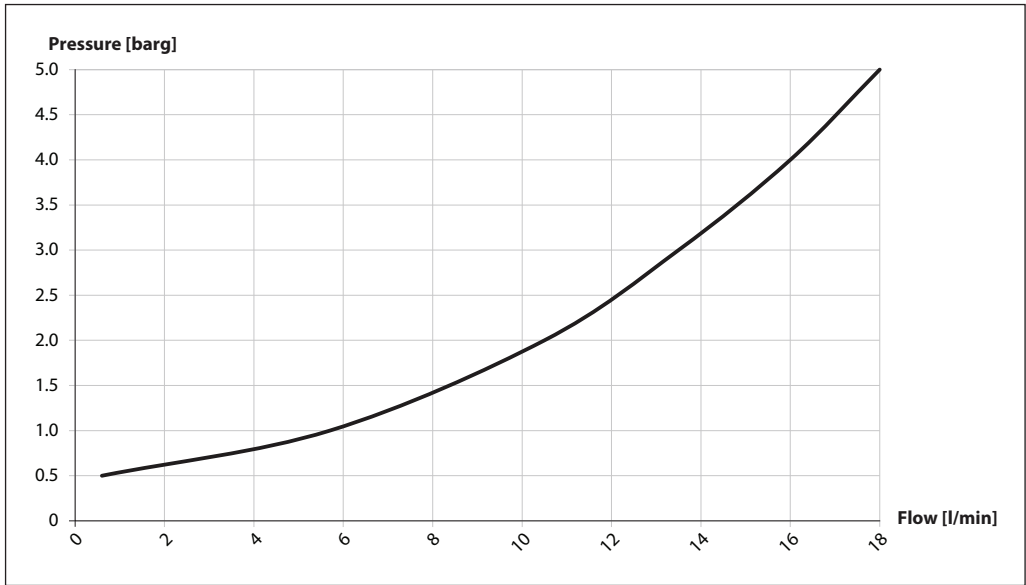
$$\text{Required rpm} = \frac{\text{Required flow} \times \text{Rated rpm}}{\text{Rated flow}}$$

5.2 APP 1.5-3.5 flow curves at 80 barg (1160 psig)



6 Flushing valve curves All pumps except APP (W) 5.1 - 10.2 are supplied with an integrated flushing valve that allows the fluid to flow from inlet to the outlet, when the pump is not running.

6.2 APP 1.5-3.5 integrated flushing valve



7. Motor requirements The power requirements can be determined using one of the following guiding equations:

$$\text{Required power} = \frac{\text{l/min} \times \text{barg}}{\text{Calc. factor}} \text{ [kW]} \text{ or } \frac{16.7 \times \text{m}^3/\text{h} \times \text{barg}}{\text{Calc. factor}} \text{ [kW]} \text{ or } \frac{0.35 \times \text{gpm} \times \text{psig}}{\text{Calc. factor}} \text{ [hp]}$$

1 hp	=	0.75 kW
1 gpm	=	3.79 l/min
1 m ³ /h	=	4.40 gpm
1 kW	=	1.34 hp
1 l/min	=	0.26 gpm
1 gpm	=	0.23 m ³ /h

7.2 Calculation factor for APP 1.5-3.5

Name	rpm	Calculation factor
APP 1.5	3450	519
APP 1.8	3450	524
APP 2.2	3450	532
APP 2.5	3000	535
APP 3.0	3450	532
APP 3.5	3000	530

8. Temperature and corrosion

8.1 Temperature

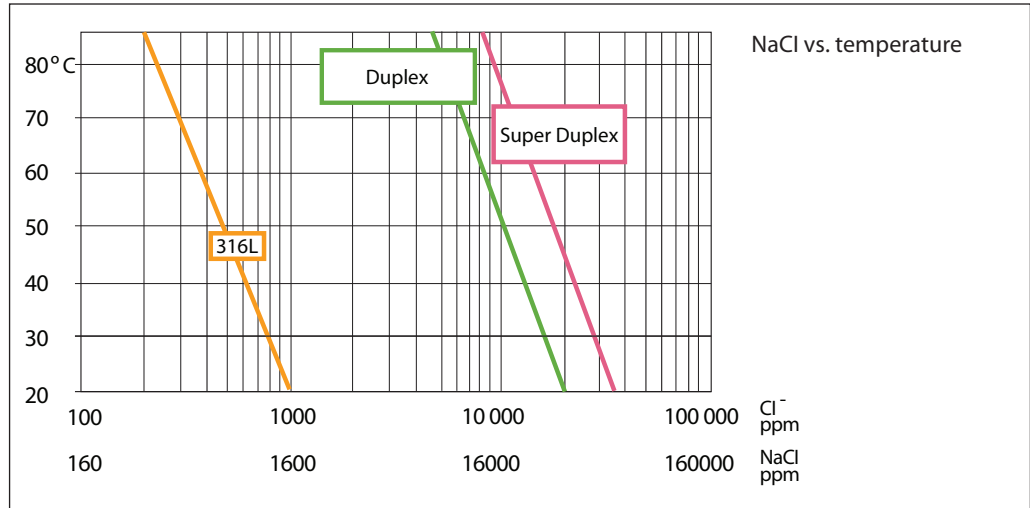
Fluid temperature: Min. +2°C to max. +50°C (Min. +35.6°F to max. +122°F)
Ambient temperature: Min. +2°C to max. +50°C (Min. +35.6°F to max. +122°F)

In case of lower operating temperatures, please contact Danfoss High Pressure Pumps.operation

stop in order to minimize the risk of crevice corrosion.

The chart below illustrates the corrosive resistance of different types of stainless steel related to NaCl concentration and temperature. The APP water pump is made of Duplex and Super Duplex.

If the water pump is operated above the Duplex line, always flush water pump with fresh water at operation stop in order to minimize the risk of crevice corrosion.

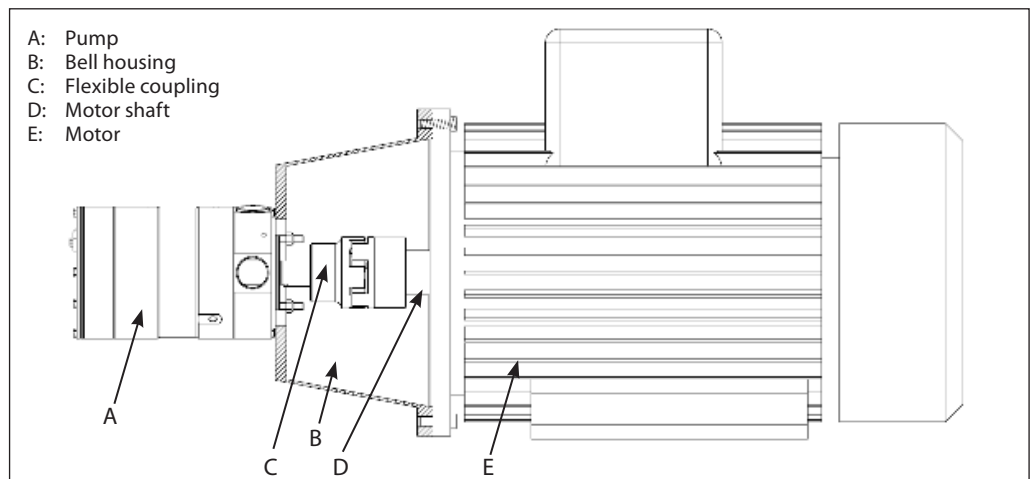


9. Installation

See example below on how to mount the pump and connect it to an electric motor or combustion engine (special coupling).

If alternative mounting is required, please contact your Danfoss sales representative for further information.

Note: Do not add any axial or radial loads to the pump shaft.



9.1 Filtration

Proper filtration is crucial for the performance, maintenance and warranty of your pump.

Protect your pump, and the application in which it is installed, and by always ensuring that all filtration specifications are met, and by always changing filter cartridges according to schedule.

Since water has very low viscosity, Danfoss APP pumps have been designed with very narrow clearances in order to control internal leakage rates and improve component performance.

To minimize wear on the pump, it is therefore essential to filter inlet water properly.

The main filter must have a filtration efficiency of 99.98% at 10 µm. We strongly recommend that you always use precision depth filter cartridges rated 10µm abs. $\beta_{10} \geq 5000$.

Please note that we do not recommend bag filters or string-wound filter cartridges, which typically have only 50% filtration efficiency. This means that out of the 100,000 particles that enter such filters, 50,000 particles pass right through; compare this to precision depth filters that are 99.98% efficient, and only allow 20 of the same 100,000 particles to pass through.

For more information on the importance of proper filtration, including explanation of filtration principles, definitions and guidance on how to select the right filter for your pump, please consult our Filtration information and specifications (Danfoss document number 521B1009).

Noise

Since the pump unit is typically mounted on a frame or bell housing the overall noise level can only be determined for a complete system. To minimize vibrations and noise throughout the system, it is therefore very important to mount the pump unit correctly on a frame with anti-vibration-dampeners, and to use flexible hoses rather than metal pipes where possible.

The noise level is influenced by:

- **Pump speed:**
High rpm generates more fluid/structure borne pulsations/vibrations than low rpm, because of higher frequency.
- **Discharge pressure:**
High pressure generates more noise than low pressure.
- **Pump mounting:**
Rigid mounting generates more noise than flexible mounting, because of structure-borne vibrations. Be sure to use dampers when mounting.
- **Connections to pump:**
Pipes connected directly to the pump make more noise than flexible hoses, because of structure-borne vibrations.

- **Variable frequency drives (VFD):**
Motors regulated by VFDs can produce more noise if the VFD does not have the right settings.

9.2 RO system with direct supply:

- Inlet line:**
- a) Dimension the inlet line to obtain minimum pressure loss (large flow, minimum pipe length, minimum number of bends/connections, and fittings with low or no pressure losses). If relevant, please consult "Parallel coupled pumps and iSaves" (180R93549)

- Inlet filter:**
- b) Install an inlet filter (1) in front of the APP pump (2). Please consult section 9.1, "Filtration" for guidance on how to select the right filter. Thoroughly clean pipes and flush system prior to start-up.

- Low pressure relief valve:**
- c) Install a low pressure relief valve (9) in order to avoid system or pump damage in case the pump stops momentarily or is spinning backwards.

- Monitoring pressure switch:**
- d) Install a monitoring pressure switch (3) between the filter (1) and the pump inlet. Set the minimum inlet pressure according to specifications described in item 4 about technical data. If the inlet pressure is lower than the minimum pressure set, the monitoring pressure switch must prevent the pump from starting or from running.

- Hoses:**
- e) Use flexible hoses (4) to minimize vibrations and noise. Please consult the Danfoss Hoses and hose fittings data sheet (521B0909) for guidance.

- Inlet pressure:**
- f) In order to eliminate the risk of cavitation and other pump damage, pump inlet pressure must always be maintained according to specifications described in item 4 about technical data.

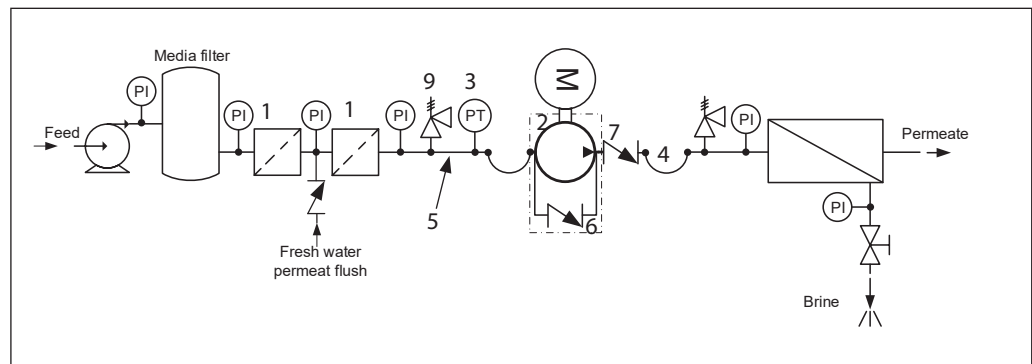
- Flushing valve:**
- g) For easy system filling and flushing, an integrated flushing valve (6) is in the APP pump (except APP (W) 5.1-10.2).

- Non-return valve:**
- h) A non-return valve (7) in outlet can be installed in order to avoid backspin of the pump. The volume of water in the membrane vessel works as an accumulator and will send flow backwards in case of the pump stops momentarily.

- i) **High pressure safety or relief valve:**
 As the Danfoss APP pump begins to create pressure and flow immediately after start-up and regardless of any counter pressure, a safety or pressure relief valve (8) should be installed after the non-return valve to prevent system damage and to avoid high pressure peaks.

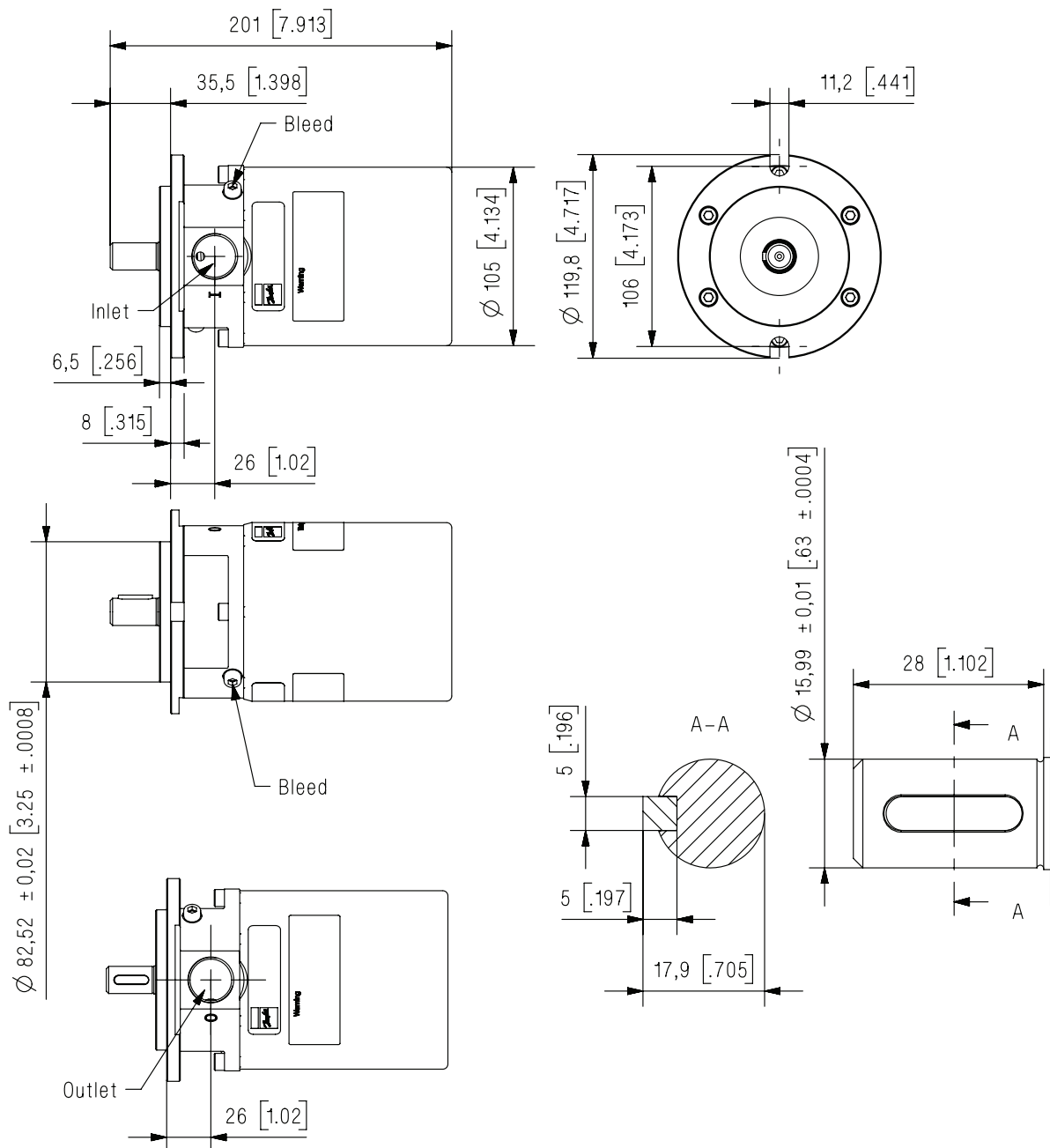
Note: If a non-return valve is mounted in the inlet line, a low-pressure relief valve is also required between the non-return valve and pump as protection against high-pressure peaks.

Preferred design - see section 9.2



10. Dimensions and connections

10.2 APP 1.5-3.5

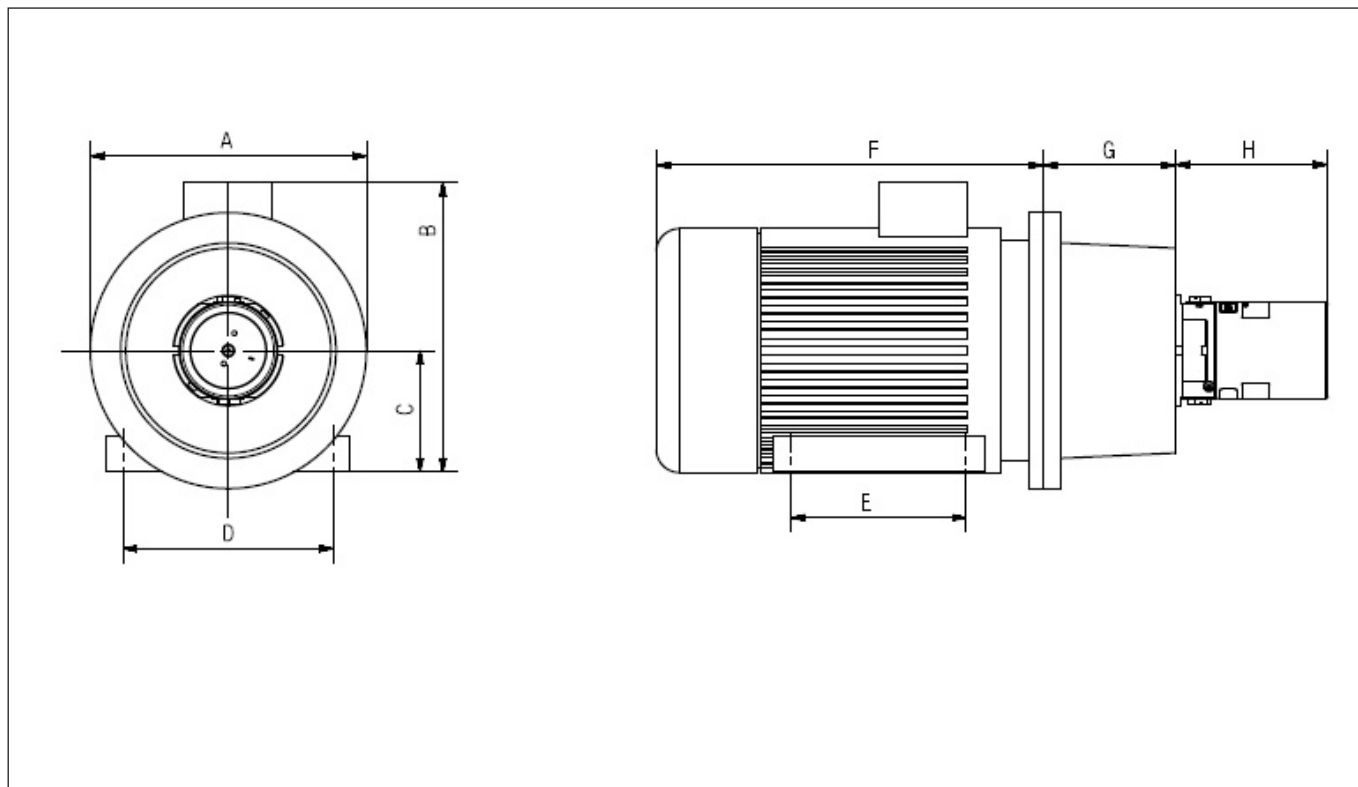


Dimensions without tolerances acc. To ISO 2768-1 designation C.

Description	APP 1.5-2.5 APP 3.0-3.5
Parallel key DIN 6885	5 x 5 x 20 mm 0.2 x 0.2 x 0.79 inch
Bleed	M6 hex key 5 mm
Inlet	G 3/4"; depth 16 mm
Outlet	G 3/4"; depth 16 mm

11. Dimensions with motor 11.1 APP 0.6-3.5 unit

The examples of assemblies with motor are only for IEC motors and couplings. Please make sure to check required motor power and dimensions when selecting size of pump and motor. For advice and calculation tool, please contact Danfoss.



Pump	A mm (inch)	B mm (inch)	C mm (inch)	D mm (inch)	E mm (inch)	F mm (inch)	G mm (inch)	H mm (inch)	IEC Electric motor
APP 0.6	200 (7.87)	245 (9.64)	90 (3.54)	140 (5.51)	100 (3.94)	265 (10.43)	100 (3.94)	131 (5.16)	1.5 kW, IEC 90S-2
APP 0.8	200 (7.87)	245 (9.64)	90 (3.54)	140 (5.51)	125 (4.92)	290 (11.42)	100 (3.94)	131 (5.16)	2.2 kW, IEC 90L-2
APP 1.0	250 (9.84)	260 (10.23)	100 (3.94)	160 (6.30)	140 (5.51)	325 (12.80)	120 (4.72)	131 (5.16)	3.0 kW, IEC 100L-2
APP 1.5	250 (9.84)	260 (10.23)	100 (3.94)	160 (6.30)	140 (5.51)	325 (12.80)	120 (4.72)	166 (6.54)	3.0 kW, IEC 100L-2
APP 1.8	250 (9.84)	290 (11.42)	112 (4.41)	190 (7.48)	140 (5.51)	340 (13.39)	120 (4.72)	166 (6.54)	4.0 kW, IEC 112M-2
APP 2.2	300 (11.81)	338 (13.31)	132 (5.20)	216 (8.50)	140 (5.51)	403 (15.87)	144 (5.67)	166 (6.54)	5.5 kW, IEC 132S1-2
APP 2.5	300 (11.81)	338 (13.31)	132 (5.20)	216 (8.50)	178 (7.01)	403 (15.87)	144 (5.67)	166 (6.54)	7.5 kW, IEC 132S2-2
APP 3.0	350 (13.78)	422 (17.40)	160 (6.30)	254 (10.0)	210 (8.27)	505 (19.88)	188 (7.40)	166 (6.54)	11 kW, IEC 160M1-2
APP 3.5	350 (13.78)	422 (17.40)	160 (6.30)	254 (10.0)	210 (8.27)	505 (19.88)	188 (7.40)	166 (6.54)	11 kW, IEC 160M1-2

13. Service

Warranty

Danfoss APP pumps are designed for long operation, low maintenance and reduced lifecycle costs.

Provided that the pump has been running according to the Danfoss specifications, Danfoss guarantees 8,000 hours service-free operation, however, max. 18 months from date of production.

If Danfoss recommendations concerning system-design are not followed, it will strongly influence the life of the APP pumps. Other factors that affect pump performance and lifetime include:

- Running the pump at speed outside specifications.
- Supplying the pump with water at temperature higher than recommended.
- Running the pump at inlet pressure outside specifications.
- Running the pump at outlet pressure outside the specifications.

Maintenance

Periodic inspections are required to ensure worn parts (if any), are replaced in due time. Operational conditions such as water quality should be taken into consideration when determining the frequency of the inspections. Danfoss recommends yearly inspections. It is recommended to order the purpose-designed tool kit.

Pump shutdown:

The APP pumps are made of Duplex/Super Duplex materials with excellent corrosion properties. It is, however, always recommended to flush the pump with freshwater when the system is shut down.

When stopping the pump for more than 1 day flush the pump with permeate by rotating the pump for 10 sec. Flushing through the flushing valve of the pump without rotating the pump is not enough for cleaning the inside of the pump. The pump can be flushed with biocide like the membranes. The biocide must be compatible with the materials used in our pumps.

Repair assistance

In case of irregular function of the APP pump, please contact Danfoss High Pressure Pumps.

Danfoss A/S

High Pressure Pumps • danfoss.com • +45 7488 2222 • highpressurepumps@danfoss.com

Any information, including, but not limited to information on selection of product, its application or use, product design, weight, dimensions, capacity or any other technical data in product manuals, catalogues descriptions, advertisements, etc. and whether made available in writing, orally, electronically, online or via download, shall be considered informative, and is only binding if and to the extent, explicit reference is made in a quotation or order confirmation. Danfoss cannot accept any responsibility for possible errors in catalogues, brochures, videos and other material. Danfoss reserves the right to alter its products without notice. This also applies to products ordered but not delivered provided that such alterations can be made without changes to form, fit or function of the product.

All trademarks in this material are property of Danfoss A/S or Danfoss group companies. Danfoss and the Danfoss logo are trademarks of Danfoss A/S. All rights reserved.

Instruction

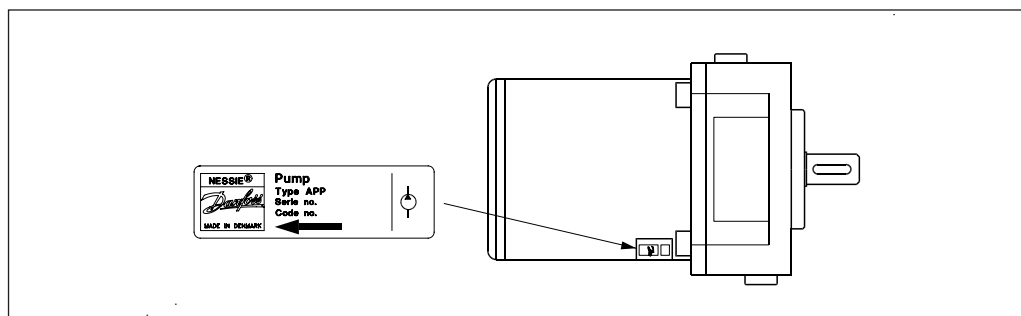
APP pumps

APP 0.6-1.0 / APP 1.5-2.5 / APP 3.0-3.5



Table of Contents	Contents	
	1.	Identification35
	2.	System design 35
	2.1	Open-ended systems with water supply from a tank 35
	2.2	Open-ended systems with direct water supply..... 35
	2.3	Problems with reversing pumps 35
	2.4	General guidelines for calculation of pressure losses 36
	2.5	General comments on..... 36
	3.	Building up the pump unit 37
	3.1	Mounting..... 37
	3.2	Direction of rotation 37
	3.3	Orientation 38
	3.4	Protection from too high pressures 38
	3.5	Connections 38
	4.	Initial start-up..... 39
	5.	Operation..... 39
	5.1	Temperature..... 39
	5.2	Pressure 39
	5.3	Dry running..... 39
	5.4	Disconnection 39
	5.5	Storage..... 39
	5.5.1	Open-ended systems with water supply from tank..... 39
	5.5.2	Open-ended systems with direct water supply..... 40
	6.	Service..... 40
	6.1	Warranty..... 40
	6.3	Repair 40

1. Identification



2. System design

The design of the system must ensure that self emptying of the pump during standstill is avoided.

The inlet pressure of the pump must never exceed the outlet pressure. This may typically occur in boosted or open-ended systems with direct water supply.

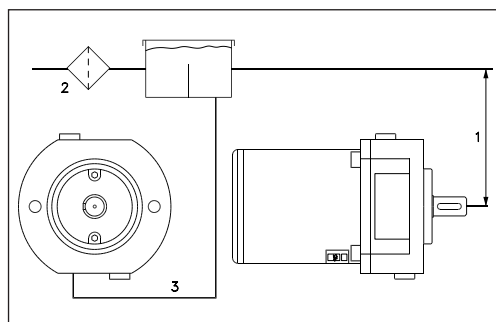
In order to avoid this it is recommended to install a pre-stressed check valve or a pressure switch in the pump inlet.

The opening pressure of the check valve must be bigger or equal to the inlet pressure.

2.1 Open-ended systems with water supply from a tank

(The numbers 1-3 refer to the drawing below.) In order to eliminate the risk of cavitation, observe the following guidelines:

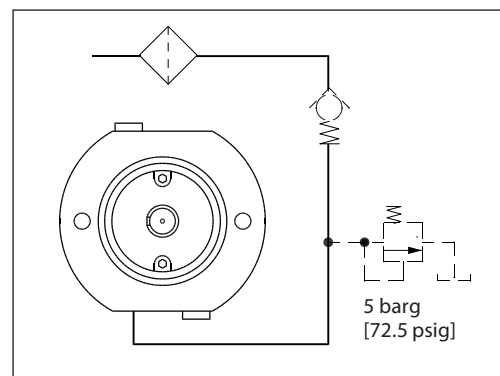
- 1) Place the tank above the pump (water level in the tank should always be above the pump).
- 2) Place the inlet filter before the tank.
- 3) Dimension the inlet line to obtain minimum pressure loss (large flow area, minimum pipe length, minimum number of bends/connections, fittings with small pressure losses).



2.2 Open-ended systems with direct water supply

The pump is supplied with water direct from a booster pump.

The water pressure must not exceed 5 barg (72.5 psig).



2.3 Problems with reversing pumps

If exposed to high pressure in the outlet while the electric motor is not energized, the pumps will start spinning backwards. This will not harm the pumps as long as the pressure in the inlet does not exceed the max. pressure of 5 barg.

If a non-return valve is mounted in the inlet line, a low-pressure relief valve will also be required. Alternatively a high-pressure check valve could be mounted in the pump discharge line to prevent the pump from reversing.

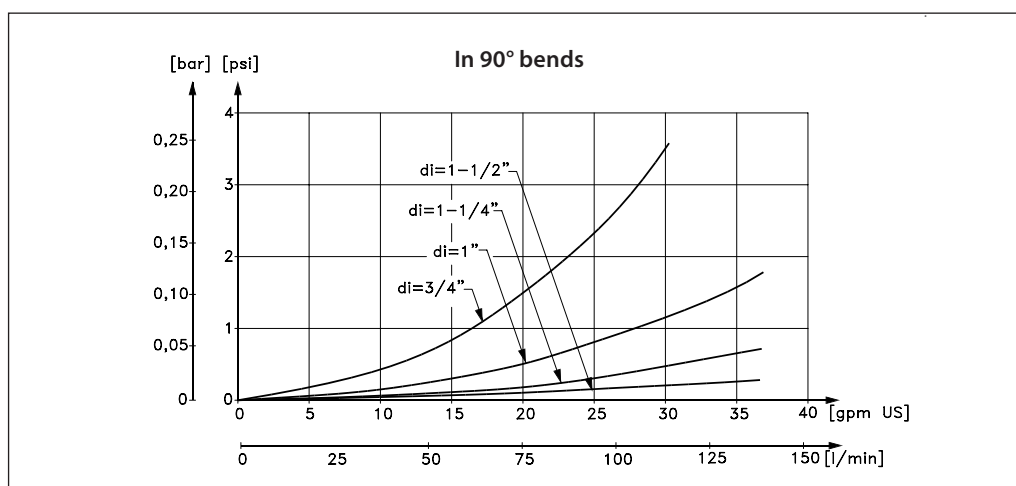
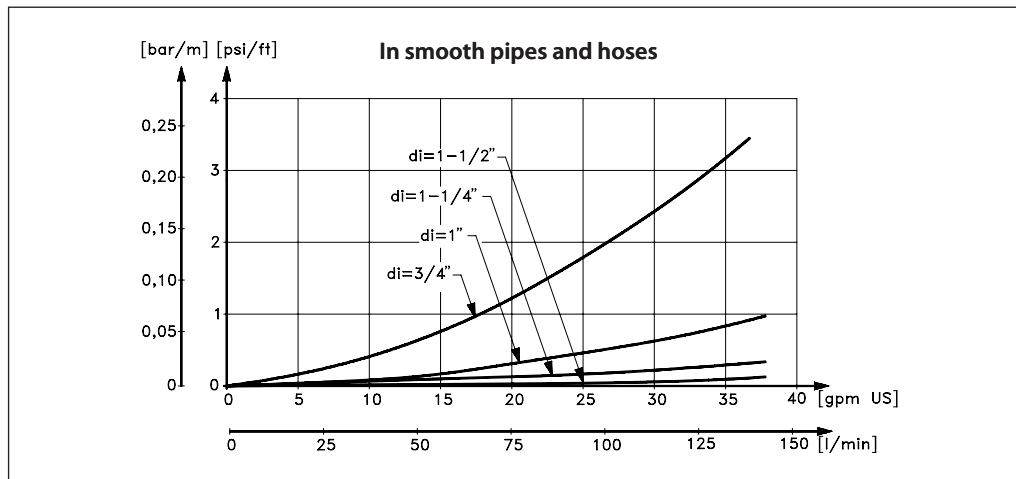
The dotted setup ensures that the inlet pressure does not exceed the 5 barg, when a non-return valve is mounted in the inlet.

2.4 General guidelines for calculation of pressure losses

In order to avoid the risk of cavitation, the inlet pressure at the pump must be in accordance with the specifications mentioned in Data sheet (521B1331).

The inlet line connection must be properly tightened, as possible entrance of air will cause cavitation.

The suction conditions can be optimized according to below guidelines.



2.5 General comments on

Filtration

A good filtration is vital to ensure a long and trouble free life of the pump.

When selecting a filter or strainer, please note that filter materials should be compatible with water, i.e. should neither corrode or dissolve. Also be aware of the electrochemical series of the applied materials.

Main filter must have a fineness of 10 μm abs. $\beta_{10} \geq 5000$. The pressure loss across the filter should be monitored.

Water tank

Must be made of corrosion-proof material such as stainless steel or plastic and must be sealed to prevent entrance of impurities from the environment.

Automatic pressure equalization between tank and surroundings must be ensured.

Inlet from the water supply and inlet to the pump should be placed in opposite ends of the tank to calm and deaerate the water, and to ensure optimum opportunity for particles to settle.

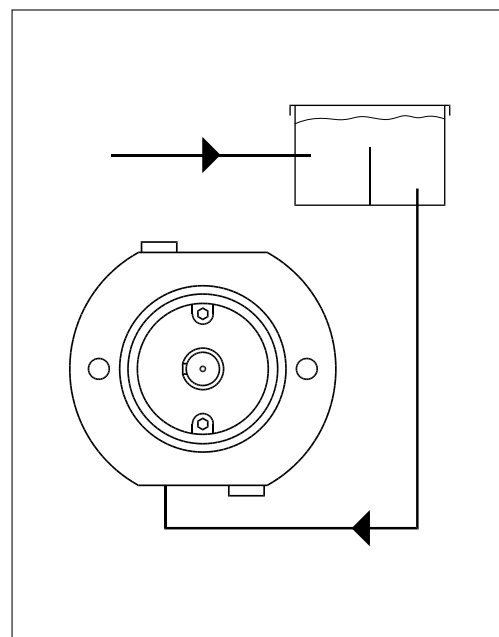
Pump suction line should be placed relatively high above the tank bottom in order to prevent settled particles from being led into the pump.

We recommend a separation ("wall") to separate the inlet from the outlet end of the tank.

Monitoring

It is recommended to continuously monitor the following conditions:

- Water level in the tank
- Filter contamination
- Pressure (inlet- and outlet side of the pump)



3. Building up the pump unit

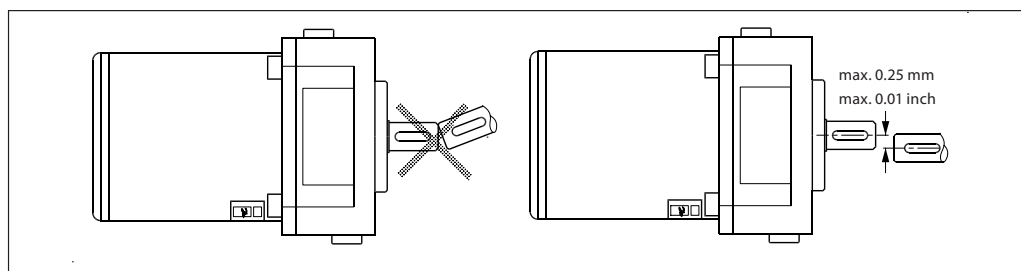
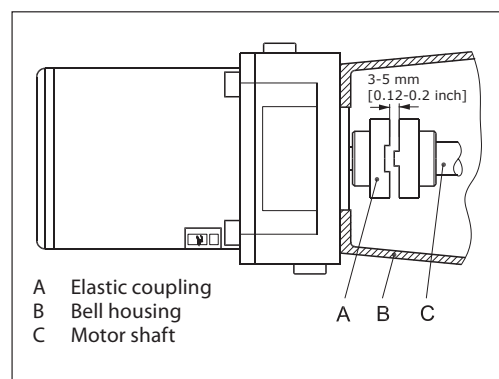
3.1 Mounting

(Please also see hints in "Right and Wrong")

If alternative mounting is desired, please contact the Danfoss High Pressure Pumps.

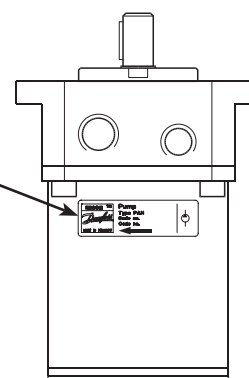
Choose proper tolerances to ensure an easy mounting of the elastic coupling without use of tools.

Please take care to observe the recommended length tolerances of the chosen coupling, as an axial force on the pump will damage the pump.



3.2 Direction of rotation

Is indicated by an arrow at the pump label.



3.3 Orientation

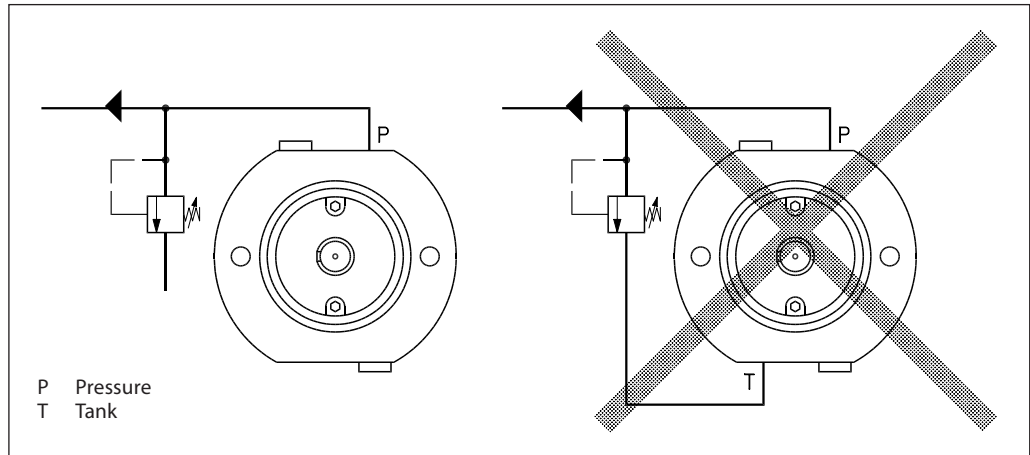
The pump can be mounted/oriented in any horizontal direction. Vertically only with the shaft pointing upwards.

The valve should be placed as close to the pump as possible. The opening characteristics of the valve must not result in peak pressures higher than 200 barg (2900 psig).

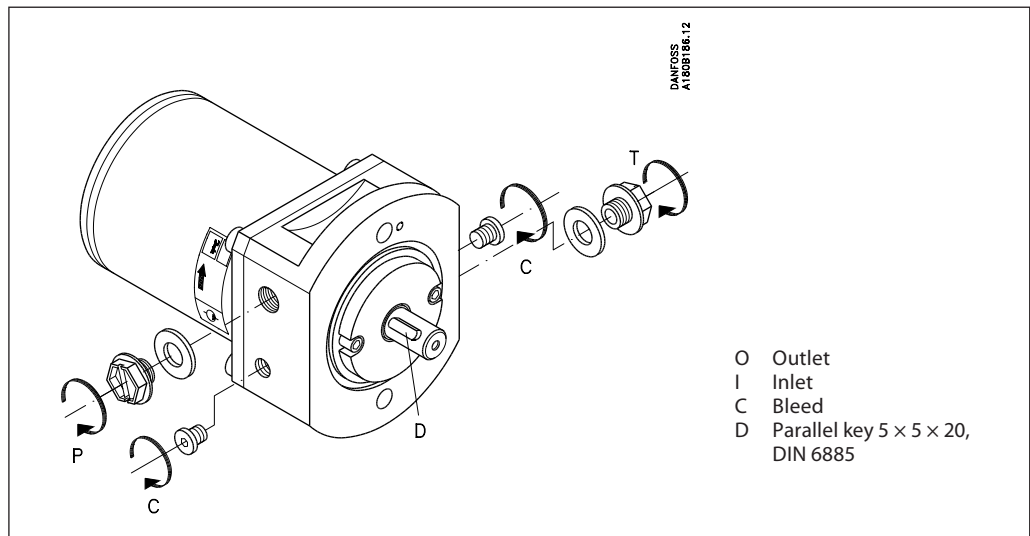
3.4 Protection from too high pressures

The pump should be protected against too high pressure by means of a pressure relief valve or a bypass/unloading valve placed on the pressure side.

The valve outlet must not be connected directly to the pump suction line. It shall be connected directly to the tank.



3.5 Connections



	APP 0.6-1.0		APP 1.5-2.5 and APP 3.0-3.5		
	O	I	O	I	C
Thread size	G 1/2 × 13	G 1/2 × 13	G 3/4 × 16	G 3/4 × 16	M6 Hexagon 5 mm key
Max tighten torque	65 Nm 48 (lbf ft)	65 Nm 48 (lbf ft)	90 Nm 66 (lbf ft)	90 Nm 66 (lbf ft)	5 Nm 3.5 (lbf ft)

Contact your fittings supplier for tightening torque requirements. Recommended torque values refer to steel washers containing a rubber sealing element.

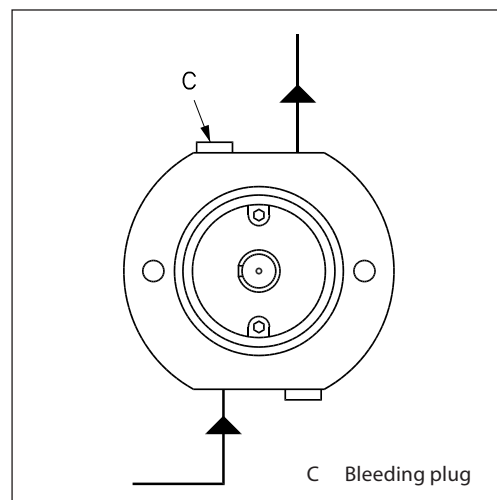
4. Initial start-up

Before start-up, loosen the top bleeding plug "C". When water appears from the bleeding plug, retighten the plug. With its inlet line connected to the water supply or the tank, the pump is now started with open outlet port.

At the initial start of the system, the pump should be run without pressure for about 5 minutes, thus removing possible impurities from pipes, hoses, etc. **However, the system should be flushed before start-up – without the connected pump.**

WARNING:

Make sure that the direction of rotation of the electric motor corresponds to the direction of rotation of the pump. Otherwise the pump will be damaged if a check valve is placed between pump and tank.



5. Operation

5.1 Temperature

Fluid temperature: Min. +2° C to max. +50° C Min. +35.6° F to max. +122° F
Ambient temperature: Min. +2° C to max. +50° C Min. +35.6° F to max. +122° F

In case of lower operating temperatures, please contact Danfoss High Pressure Pumps.

5.2 Pressure

The inlet pressure must be min. 0.5 barg (7.25 psig) and max. 5 barg (72.5 psig). At lower pressures the pump will cavitate, resulting in damage to the pump.

Max. pressure on the pump's outlet line should be limited at 80 barg (1160 psig) continuously. Short-term pressure peaks (e.g. in connection with closing of a valve) of up to 100 barg (1450 psig) are acceptable.

NB:

The pump unit should include a pressure gauge on the high pressure side.

5.3 Dry running

When running, the pump must always be connected to the water supply in order to avoid damage if it should run dry.

In systems with water tank it is recommended to build in a level gauge in the tank to avoid the risk of running dry.

5.4 Disconnection

If the inlet line is disconnected from the water supply, the pump will be emptied of water through the disconnected inlet line.

When starting up again, follow the bleeding procedure described under section 4: Initial start up.

5.5 Storage

Frost protection:

Storage temperature: Min. -40° C to max. +70° C Min. -40° F to max. +158° F

When preparing the pump for long-term storage or for temperatures below the freezing point, flush the pump with an anti-freeze medium type monopropylene glycol to prevent internal corrosion or frost in the pump.

For further information on anti-freeze media, please contact Danfoss High Pressure Pumps.

Recommended procedure:

5.5.1 Open-ended systems with water supply from tank

1. Empty the tank of water and empty the pump housing through the lower bleeding plug. When the pump is empty, retighten the plug.
2. Through the upper bleeding plug, fill the pump housing with anti-freeze medium. Pour anti-freeze medium into the tank. Connect a hose to the outlet of the pump and lead the other end of the hose back to tank.
3. Quickly start and stop the pump. Make sure that the pump does not run dry. The pump is now protected against internal corrosion and frost.

5.5.2 Open-ended systems with direct water supply

1. Disconnect the water supply to the pump.
2. Through the lower bleeding plug, empty the pump housing of water and close it again.
3. Connect the pump to a tank of e.g. 25 litre (6 gal.) of anti-freeze additive. Connect a hose to the inlet port of the pump and via another hose return the flow from the outlet port to the tank with anti-freeze additives.
4. Quickly start and stop the pump. Make sure that the pump does not run dry. The pump is now protected against internal corrosion and frost.

Storage:

Storage of the pump that have been in operation:

For shorter periods of storage flush the pump with permeate rotating the pump for 10 sec. empty permeate and store.

For long term storage (more than 2 months) Danfoss recommends servicing the product and clean any biological growth of the surfaces. Store the pump dry without water inside.

6. Service

6.1 Warranty

Danfoss APP pumps are designed for long operation, low maintenance and reduced lifecycle costs.

Provided that the pump has been running according to the Danfoss specifications, Danfoss guarantees 8,000 hours service-free operation, however, max. 18 months from date of production. If Danfoss recommendations concerning system-design are not followed, it will strongly influence the life of the APP pumps.

6.2 Maintenance

After 8,000 hours of operation, it is recommended to inspect the pump and change any worn parts, e.g. pistons.

This is done in order to prevent a potential breakdown on the pump. If the parts are not replaced, more frequent inspection is recommended according to our guidelines.

Pump shutdown:

The APP pumps are made of Duplex/Super Duplex materials with excellent corrosion properties. It is however, always recommended to flush the pump with fresh water when the system is shut down.

When stopping the pump for more than 1 day, flush the pump with permeate by rotating the pump for 10 sec. Flushing through the flushing valve of the pump without rotating the pump is not enough for cleaning the inside of the pump. The pump can be flushed with biocide like the membranes. The biocide must be compatible with the materials used in our pump (materials can be found in the parts list in the Operating Guide)

6.3 Repair

In case of irregular function of the APP pump, please contact Danfoss High Pressure Pumps sales organisation.

Danfoss A/S
High Pressure Pumps
Nordborgvej 81
DK-6430 Nordborg
Denmark

Danfoss can accept no responsibility for possible errors in this document, brochures and other printed material. Danfoss reserves the right to alter its products without notice. This also applies to products already in circulation and that may therefore not be made without any essential changes being necessary to specifications already agreed. All trademarks in this material are property of the respective companies. Danfoss and the Danfoss logo are trademarks of Danfoss A/S. All rights reserved.



Electric Motors

Motor Manual

hoyermotors.com

Manual

HOYER
MOTORS

Motor Manual

General

This manual concerns the following types of standard induction motors from Hoyer:

HMA3, HMC3, HMA2, HMC2, HMD, HMT, MS, Y2E1, Y2E2, YDT
 These motors are manufactured in accordance with IEC/EN 60034-4 and IEC/EN 60072.

Motors are rated for the ambient temperature range -20°C to +40°C and site altitudes ≤1000 m above sea level.

Low-voltage motors are components for installation in machinery. They are CE marked according to the Low Voltage Directive 2014/35/EU.

Motors not fulfilling the IE3 efficiency level must be equipped with a variable speed drive when used in EU.

Transport and storage

Check the motor for external damage immediately upon receipt and, if found, inform the forwarding agent right away. Check all rating plate data, and compare it with the requirement of the motor.

Turn the shaft by hand to check free rotation, remove transport locking if used.

Transport locking must be used again for internal transport also. It is also important that transport locking is used when motors are transported mounted on equipment.

All motors should be stored indoors, in dry, vibration- and dust-free conditions.

Lifting eyebolts must be tightened before use. Damaged eyebolts must not be used, check before use. Lifting eyes at motor must not be used to lift the motor when it is attached to other equipment.

Before commissioning, measure the insulation impedance. If values are ≤ 10MΩ at 25°C, the winding must be oven dried. The insulation resistance reference is halved for each 20°C rise in motor temperature.

It is recommended that shafts are rotated periodically by hand to prevent grease migration.

Installation

The motor must be fixed on a stable, clear and flat foundation. It must be sufficiently rigid to withstand possible short circuit forces.

It is important to ensure that the mounting conditions do not cause resonance with the rotational frequency and the doubled supply frequency.

Only mount or remove drive components (pulley, coupling,

etc.) using suitable tools, never hit the drive components with a hammer as this will cause damage to the bearing.

The motor are balancing with half key, ensure that the drive components are also the same.

Correct alignment is essential to avoid bearing, vibration and shaft failure.

Use appropriate methods for alignment.

Re-check the alignment after the final tightening of the bolts or studs.

Check that drain holes and plugs face downwards. We recommend opening the drain hole for motors placed outdoors and not running 24 hours / day, so that the motor can breathe, thus ensuring a dry motor.

Electrical connection

Work is only permitted to be carried out by qualified specialists and must to be carried out in accordance with local regulations.

Before work commences, ensure that all power is switched off and cannot be switched on again. This also applies to the auxiliary power circuits, e.g. anti-condense heaters.

Check that supply voltage and frequency are the same as rated data.

Motors can be used with a supply deviation of ± 5% voltage and ± 2% frequency, according to IEC60034-1.

Connection diagrams for main supply and accessory as PTC or heater are located inside the terminal box.

Connections must be made in such a way as to ensure that a permanently safe electrical connection is maintained, both for the main supply and the earth connection.

We recommend that crimped connections are made in accordance with IEC 60352-2.

Tightening torques for terminal board screws:

Thread	M5	M6	M8	M10	M12	M16	M20	M24
T.(Nm)	2.5	3.5	7	12	18	35	55	80

Ensure that the terminal box is clean and dry.

Unused glands must be closed with blind caps.

Check the terminal box gasket before it is remounted.

Maintenance

Inspect the motor at regular intervals, keep it clean and ensure free ventilation air flow, check the condition of shaft seals and replace if necessary. Both electrical and mechanical

connections must be checked and tightened if necessary. Bearing size and type are specified on the rating plate. Motor types HMA3 and HMC3 is as standard with lifetime greased bearings in motors size ≤180 for cast iron and size ≤132 for aluminium. Motor types HMA2 and HMC2 is as standard with lifetime greased bearing in motors size ≤225. Motor types MS and Y2E is as standard with lifetime greased bearing in motors size ≤160.

Typical duty hours for lifetime lubricated bearings.

Frame size	Poles	Typical lifetime
56 - 160	2 - 8	40,000h
180	2	35,000h
200	2	27,000h
225	2	23,000h
180 - 225	4 - 8	40,000h

Motors with a re-greasing system must be lubricated with high quality lithium complex grease, NLGI grade 2 or 3, with a temperature range of between -40°C to +150°C. Motors are normal fitted with a data plate with greasing information; if it is missing use the following re-greasing intervals.

Frame size	Grease (g)	2 pole (h)	4 pole (h)	6 pole (h)	8 pole (h)
160	20	4200	7000	8500	8500
180	20	4200	7000	8500	8500
200	25	3100	6500	8500	8500
225	25	3100	6500	8500	8500
250	35	2000	6000	7000	7000
280	35	2000	6000	7000	7000
315	50	1500	5500	6500	6500
355	60	1000	4000	5000	6000
400	80	800	3000	4000	6000

Grease the motor while running, open the grease outlet plug and let the motor run 1-2 hours before the outlet grease plug is closed again.

Grease the motor for the first time during commissioning.

The following applies in general for both lifetime lubricated and re-lubricated bearings:

At 60Hz the time will be reduced by app. 20%.

Data for vertically mounted motors are half of the above values.

The table values are based on an ambient temperature of 25°C. The values must be halved for every 15K increase in bearing temperature.

Higher speed operations, e.g. frequency converter drive will require shorter greasing intervals. Typically, doubling the speed will reduce the values by 50%.

Special note for Atex Zone 22 and nA motors

Designation of motor according to IEC standard:

II 3D Ex tc IIIB T120°C

II 3G Ex nA IIC T3

The hazardous 3-phase asynchronous motors are in accordance with International standard IEC 60079-31 and IEC 60079-15.

Only one electrical installation may be installed in one specified area (zone).

Only certificated cable glands may be used. Unused glands must be closed.

Connections must be made in such a way as to ensure that a permanently safe electrical connection is maintained, both for the main supply and earth connection.

Installations must be in accordance with actual standards for installation in hazardous area.

It is recommended that the IEC standard is followed according to temperature and dust on the motor surface.

The use of motors with so much surface dust that the motor temperature increases is not permitted.

Regularly cleaning is recommended.

The radial shaft sealing ring is part of the ATEX certification. It is important that the ring is always intact.

The shaft sealing must be regularly checked, and if dry it must be lubricated. It is recommended that the seal is re-lubricated regularly.

Always use the original seal ring when replaced.

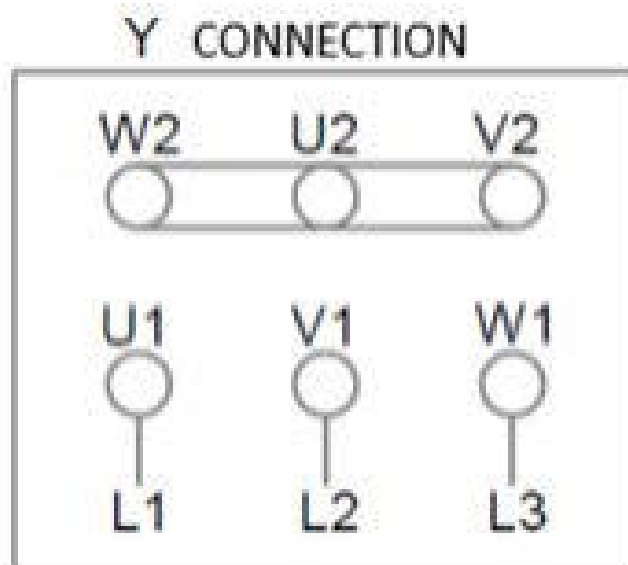
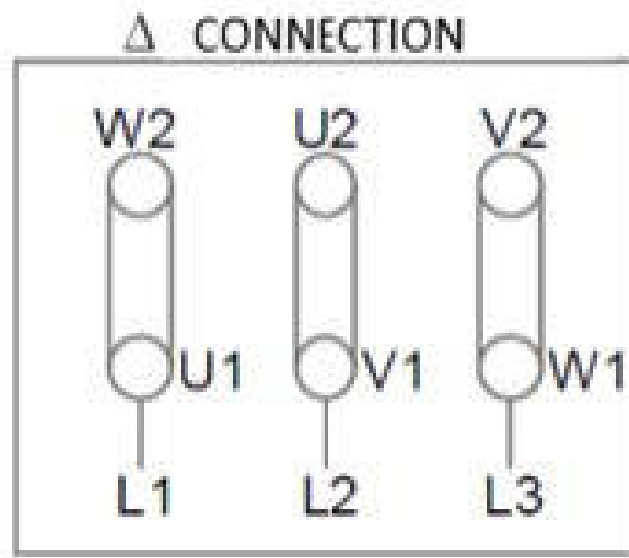
Replacing bearings also means replacing the seals.

All machines must be inspected regularly for mechanical damage.

The user is responsible for changing parts in accordance with the lifetime of parts, in particular: bearings, grease and lubrication of shaft sealing.

Maintenance, repairs and replacement on this type must only be carried out by qualified specialists.

Connection diagram
Anschlußdiagramm
Anslutningdiagramm
Forbindelsesdiagram
Aansluitdiagram
Connection
Conexión
Collegamento
Schemat polacsen



EU Declaration of Conformity

The Manufacturer: SVEND HØYER A/S
Over Hadstensevej 42
DK 8370 Hadsten
Denmark

Hereby declares that

The products: HOYER MOTORS, 3-phase induction motors

Aluminum motors	MS 56 - 180 HMAx 56 - 180
Cast iron motors	Y2E2 80 - 400 HMCx 80 - 400

HOYER MOTORS, 1-phase induction motors

Aluminum motors	ML 56 - 112 MY 63 - 112
-----------------	----------------------------

Are in conformity with the following:

Standards: IEC/EN 60034 (All relevant standards on the IEC/EN 60034 series)
Directive: Low Voltage Directive 2014/35/
EU

Motor type HMAx and HMCx is also conformity with:

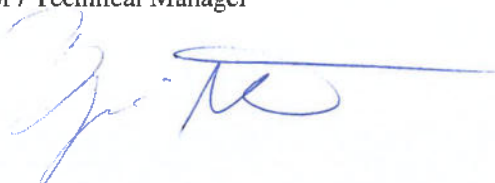
Standards: IEC/EN 60079-0:2018, IEC/EN 60079-0/A11:2013,
IEC/EN 60079-15:2010, IEC/EN 60079-31:2014
Directive: Eco design for electrical motors 2009/640/EC and 2014/4EU
ATEX directive 2014/34/EU
Ex II 3D Ex tc IIIB T120°C
Ex II 3G Ex nA IIC T3
CE marking: CE

This declaration of conformity is issued under the sole responsibility of the manufacturer.

I hereby declare that the equipment's named above have been designed to comply with the relevant sections of the above referenced specifications.

Signed by: Bjarne Nør / Technical Manager

December 2018:



1/3

x = 2, 3

HOYER

EXCEEDING EXPECTATIONS

Hoyer Motors, Motor Manual, April 2019

Head Offices

Denmark

Over Hadstensevej 42 · DK-8370 Hadsten
T +45 86 98 21 11 · F +45 86 98 17 79
CVR no. 17 63 06 95
hoyermotors@hoyermotors.com
hoyermotors.com

China

19 Jingwu Middle Road · Beilun District
Ningbo 315821 · Zhejiang
T +86 574 26 28 15 77 · F + 86 574 2628 1573
hoyermotors@hoyermotors.cn
hoyermotors.cn

Branch Offices

Germany

Landsberger Straße 155 · 80687 München
T +49 89 700 88 235 · F +49 89 543 56 333
germany@hoyermotors.com
hoyermotors.com

Sweden

Liljeholmsstranden 5 · PO box 44017
SE-100 73 Stockholm
T +46 8 446 877 13
sweden@hoyermotors.com
hoyermotors.com

Benelux

Vasteland 78 · 3011 BN, Rotterdam
Tel. +31 10 420 35 20 · Fax.+31 10 420 44 51
benelux@hoyermotors.com
hoyermotors.com

Korea

302ho · Code square · 3150-1 · Daejeo 2-dong
Gangseo-gu · Busan · Korea
T +82 51 996 0251 · F +82 51 996 0252
korea@hoyermotors.com
hoyermotors.com

Important notice. Text and data in this catalogue are not binding and we reserve the right to implement changes without further notice.

Instruction

APP pumps

APP 0.6 - 3.5
Recommended service intervals



Instruction | Recommended service intervals for APP 0.6 - 3.5 pumps

Table of Contents	1.	General information.....	48
	2.	Design/features	48
	3.	Appendix 1	49

1. General information

This guideline provides information on the recommended service intervals. The recommendation is based upon good engineering practice and on experience gained from operation even under extreme conditions.

The recommendation is for guidance only.

2. Design/features

Danfoss APP pumps are designed for long operation and low maintenance and life cycle costs.

Provided that the pump has been running according to the Danfoss specifications, Danfoss guarantees one year service-free operation, however, max. 18 months from date of production. After one year of operation it is recommended to inspect the pump and replace worn parts, if any.

If the Danfoss recommendations concerning system-design (see our data sheet) are not followed, the service life of the APP pumps might be affected.

The recommended service intervals on the different parts in the APP pumps appear from the table below:

Pos.	Qty.	Description	Material	Service interval APP 0.6 - 3.5
1	1	Housing, main bearing	Duplex, PEEK	No need for service
11, 125, 211*	1	Mounting flange/ end flange	Wetted part: Duplex Dry part: AISI 316L	No wear part
121, 181*	1	Port flange	Duplex	No wear part
31	1	Swash plate	Super Duplex	40,000 hours
66	5/7/9	Piston	Super Duplex and PEEK	Recommended inspection on a yearly basis and evaluated acc. to app. 1 Replace after 16,000 hrs.
92	1	Valve plate	Super Duplex	24,000 hours
91	1	Port plate	Super Duplex, PEEK	24,000 hours
61	1	Cylinder barrel	Super Duplex	40,000 hours
65	1	Retainer plate	Super Duplex	40,000 hours
64	1	Retainer ball	Super Duplex	40,000 hours
71	1	Retainer guide	Super Duplex	40,000 hours
62	1/4	Spring	Duplex	40,000 hours
63	1	Spring guide	Duplex or PP	40,000 hours
142	1	Stop for shaft seal	PP	No wear part
124, 215*	1	Shaft seal	Hastelloy and NBR	24,000 hours
125	1	Cover/flange for shaft seal	Super Duplex	No wear part
93	5/7/9	Back-up ring	PTFE	8,000 hours
*		O-ring (overall)	NBR	8,000 hours
*		Screw (overall)	AISI 316	8,000 hours
*		Pin (overall)	AISI 316, Duplex or PEEK	No wear part
152	1	Valve cone (flushing valve)	Duplex or PEEK	40,000 hours
3, 129*	2	Bleeding screw	Duplex	No wear part
67	1	Key	AISI 316	40,000 hours

* depends on pump size

Instruction | Recommended service intervals for APP 0.6 - 3.5 pumps

3. Appendix 1

Pistons:
The pistons are the heart of the pump regarding service.

If the pistons break down, the pump will suffer a breakdown.

In case of doubt - the pistons must be replaced.

The pictures below is ment as a guideline for evaluating the wear of the sliding surface.



Cavitation of the piston shoes.
New inspection is required in 3,000-4,000 hours.



Cavitation of the piston shoes.
All pistons must be replaced within the next 500-1,000 hours.



Cavitation of the piston shoes.
All pistons must be replaced within the next 100-200 hours.



Cavitation of the piston shoes.
All pistons must be replaced immediately.



Abrasive wear of the piston shoes.
All pistons must be replaced immediately.

Danfoss A/S

High Pressure Pumps • danfoss.com • +45 7488 2222 • highpressurepumps@danfoss.com

Any information, including, but not limited to information on selection of product, its application or use, product design, weight, dimensions, capacity or any other technical data in product manuals, catalogues descriptions, advertisements, etc. and whether made available in writing, orally, electronically, online or via download, shall be considered informative, and is only binding if and to the extent, explicit reference is made in a quotation or order confirmation. Danfoss cannot accept any responsibility for possible errors in catalogues, brochures, videos and other material. Danfoss reserves the right to alter its products without notice. This also applies to products ordered but not delivered provided that such alterations can be made without changes to form, fit or function of the product.

All trademarks in this material are property of Danfoss A/S or Danfoss group companies. Danfoss and the Danfoss logo are trademarks of Danfoss A/S. All rights reserved.

Parts list

APP pumps

APP 0.6-46 / APM 0.8-2.9 /
APP W 5.1-10.2



Table of Contents

Table of Contents

1.	General	53
4.	Parts list APP 1.5-2.5 and APM 1.8-2.9	54
5.	Exploded view APP 1.5-2.5 and APM 1.8-2.9	55
6.	Parts list APP 3.0-3.5	56
7.	Exploded view APP 3.0-3.5	57
22.	Tool sets	58

1. General

This parts list provides an overview of the content of the various service sets as well as exploded views for both non ATEX and ATEX certified pumps.
ATEX certified pumps are indicated by Ex in the designation.

Non ATEX	ATEX
APP 1.5-2.5	APP 1.5-2.5 Ex
APM 1.8-2.9	N/A
APP 3.0-3.5	APP 3.0-3.5 Ex

**4. Parts list
APP 1.5-2.5 and
APM 1.8-2.9**

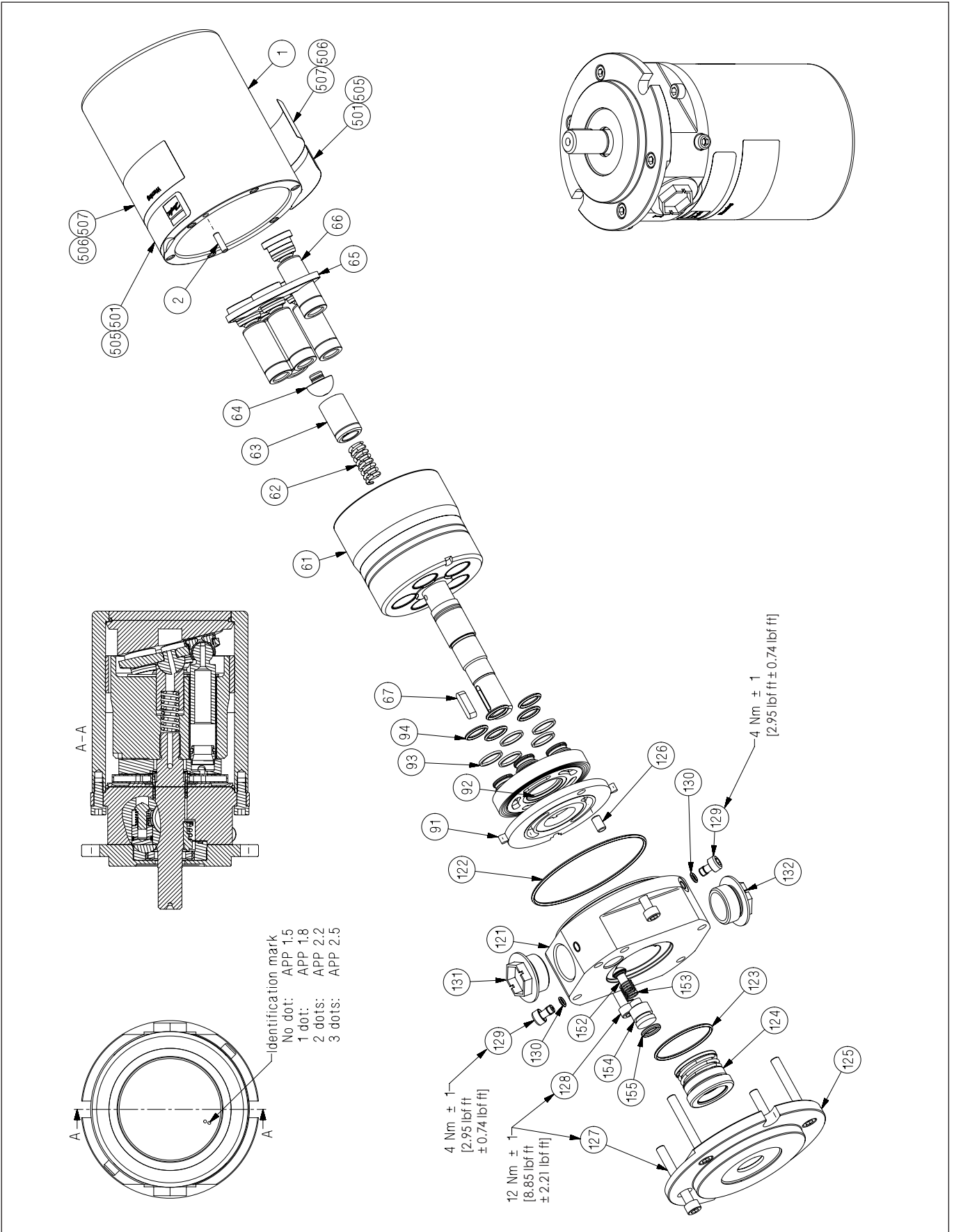
Note:
The parts listed are not sold separately, only in various kits

Parts for APM 1.8-2.9 are equivalent to the parts for APP 1.5-2.5 except for the valve plate sets.

Exploded view, see next page.

Pos.	Qty.	Designation	Material	180B4147 – Seal set (APP 1.5-2.5)	180B4146 – Cylinder barrel set (APP 1.5-2.5)	180B4145 – Valve plate set (APP 1.5-2.5)	180F4007 – Valve plate set (APM 1.8 - 2.9)	180B4177 – Retainer set (APP 1.5-1.8 - APM 1.8-2.0)	180B4144 – Retainer set (APP 2.2-2.5 - APM 2.5-2.9)	180B4143 – Piston set (APP 1.5-2.5)	180B4136 – Flushing valve set (APP 1.5 - 3.5)
1	1	Housing	Duplex / PEEK								
2	1	Pin (Ø4x14)	AISI 316	x							
61	1	Cylinder barrel	Super Duplex / PEEK		x						
62	1	Spring	Duplex					x	x		
63	1	Spring guide	PEEK					x	x		
64	1	Retainer ball	Super Duplex					x	x		
65	1	Retainer plate	Super Duplex					x	x		
66	5	Piston	Super Duplex / PEEK							x	
67	1	Key (5x5x20)	AISI 316	x							
91	1	Port plate	Super Duplex / PEEK			x	x				
92	1	Valve plate	Super Duplex			x	x				
93	5	Back-up ring	PTFE	x		x	x				
94	5	O-ring (Ø13x2)	NBR	x		x	x				
121	1	Port flange	Duplex								
122	1	O-ring (Ø83x2)	NBR	x							
123	1	O-ring (Ø40x2)	NBR	x							
124	1	Shaft seal	AISI 316 / NBR	x							
125	1	Mounting flange	Wetted part: PP Dry part: AISI 316								
126	1	Pin (Ø6x10)	PEEK	x							
127	4	Screw (M6x45)	AISI 316	x							
128	2	Screw (M6x16)	AISI 316	x							
129	2	Bleeding plug	Duplex	x							
152	1	Valve cone	PEEK								x
153	1	Spring	Duplex								x
154	1	Plug/guide	Duplex								x
155	1	O-ring (Ø11.11x1.78)	NBR	x							x
	1	Instruction		x	x	x	x	x	x	x	x

5. Exploded view
APP 1.5-2.5 and APM 1.8-2.9



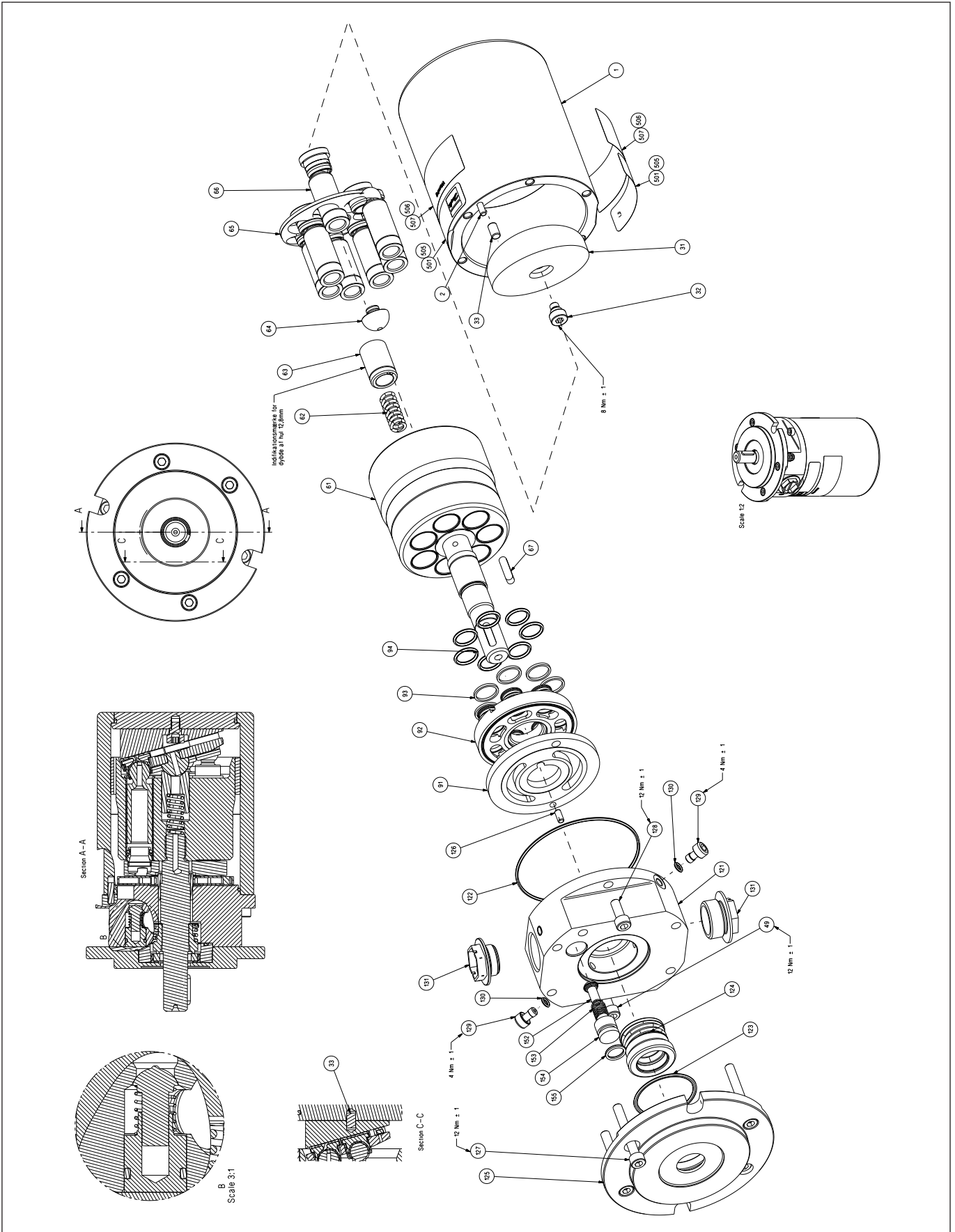
**6. Parts list
APP 3.0-3.5**

Note:
The parts listed are not sold separately, only in various kits.

Exploded view, see next page.

Pos.	Qty.	Designation	Material	180B4153 – Seal set (APP 3.0-3.5)	180B4152 – Cylinder barrel set (APP 3.0-3.5)	180B4151 – Valve plate set (APP 3.0-3.5)	180B4150 – Retainer set (APP 3.0-3.5)	180B4149 – Piston set (APP 3.0-3.5)	180B4134 – Swash plate set (APP 3.0)	180B4135 – Swash plate set (APP 3.5)	180B4136 – Flushing valve set (APP 3.5)
1	1	Housing	Duplex / PEEK								
2	1	Pin (Ø4x14)	AISI 316	x							
31	1	Swash plate	Super Duplex						x	x	
32	1	Centre bolt	Duplex						x	x	
33	1	Pin (Ø6x10)	PEEK	x					x	x	
61	1	Cylinder barrel	Super Duplex / PEEK		x						
62	1	Spring	Duplex				x				
63	1	Spring guide	PEEK				x				
64	1	Retainer ball	Super Duplex				x				
65	1	Retainer plate	Super Duplex				x				
66	7	Piston	Super Duplex / PEEK					x			
67	1	Key (5x5x20)	AISI 316	x							
91	1	Port plate	Super Duplex / PEEK			x					
92	1	Valve plate	Super Duplex			x					
93	7	Back-up ring	PTFE	x	x						
94	7	O-ring (Ø13x2.0)	NBR	x	x						
121	1	Port flange	Duplex								
122	1	O-ring (Ø83x2)	NBR	x							
123	1	O-ring (Ø40x2)	NBR	x							
124	1	Shaft seal	AISI 316 / NBR	x							
125	1	Mounting flange	Wetted parts: PP Dry parts: AISI 316L								
126	1	Pin (Ø4x9)	PEEK	x							
127	4	Screw (M6x45)	AISI 316	x							
128	2	Screw (M6x16)	AISI 316	x							
129	2	Bleeding plug	Duplex	x							
130	2	O-ring (Ø4.5x1.5)	NBR	x							
152	1	Valve cone	PEEK								x
153	1	Spring	Duplex								x
154	1	Plug/guide	Duplex								x
155	1	O-ring (Ø11.11x1.78)	NBR	x							x
		Instruction		x	x	x	x	x	x	x	x

7. Exploded view
APP 3.0-3.5



22. Tool sets

Note:
The parts listed are not sold separately, only in various kits.

Designation	180B4148 – Tool set (APP 1.5-3.5)
Shaft bush	
Press bush	
Drift	
Torx (T30)	
Shaft bush (Ø18)	x
Press bush (Ø18)	x
Allen key (4 mm)	
Allen key (5 mm)	x
Allen key (6 mm)	
Shaft bush (Ø35)	
Shaft seal extractor (Ø35)	
Press bush (Ø35)	
Adjustable pin wrench	
Combination wrench (10 mm)	
Combination wrench (13 mm)	
Nut (M8x6.5x13)	
Guide bolt (M8x140)	
Shaft seal extractor (Ø45)	
Press bush (Ø45)	
Eye bolt (M8)	
Press bush for valve plate	
Stop for retainer plate	
Screw (M8x20)	
Screw (M8x70)	

Danfoss A/S
High Pressure Pumps
Nordborgvej 81
DK-6430 Nordborg
Denmark

Danfoss can accept no responsibility for possible errors in catalogues, brochures and other printed material. Danfoss reserves the right to alter its products without notice. This also applies to products already on order provided that such alterations can be made without subsequential changes being necessary in specifications already agreed. All trademarks in this material are property of the respective companies. Danfoss and the Danfoss logotype are trademarks of Danfoss A/S. All rights reserved.

Guideline

Trouble shooting guide

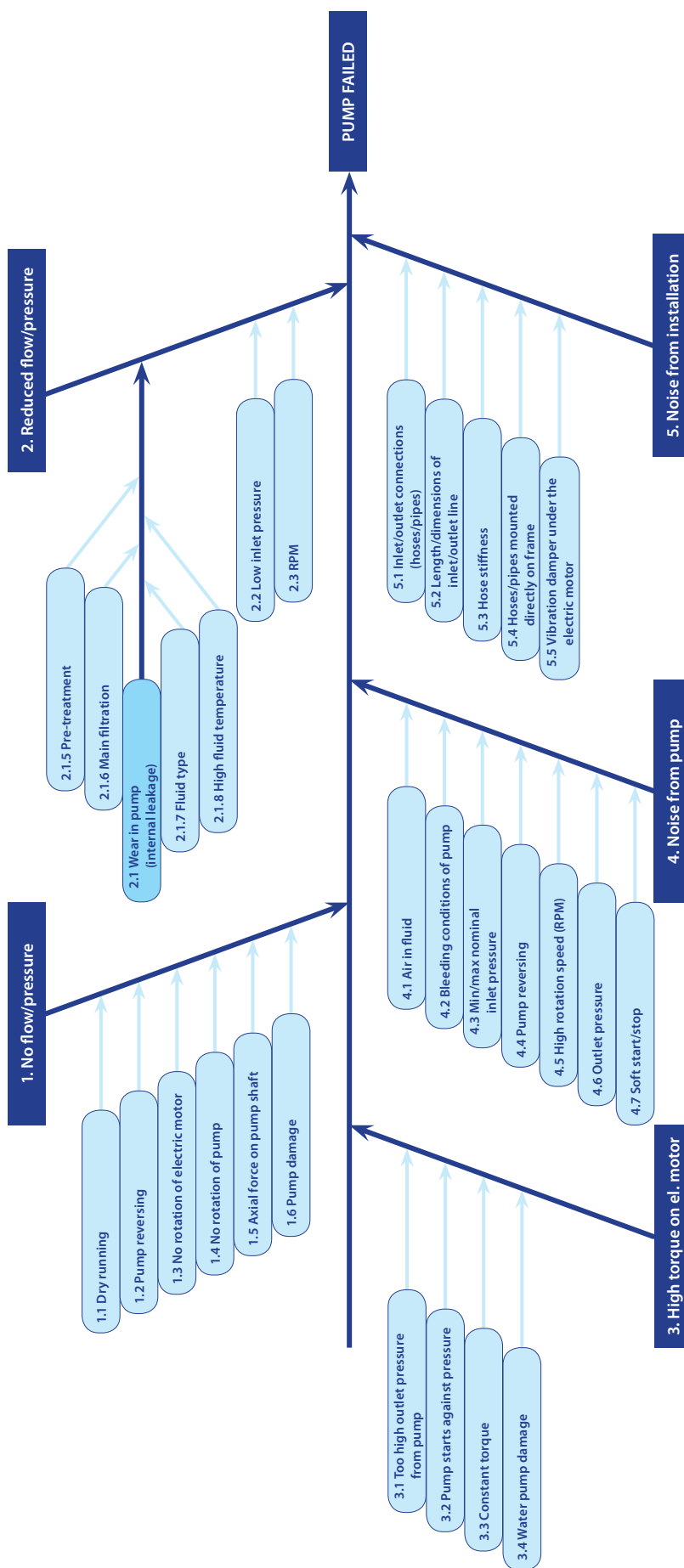
APP, APP S and APP S 674 pumps

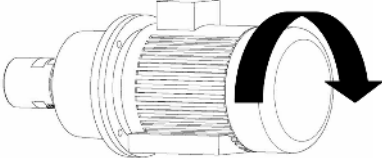
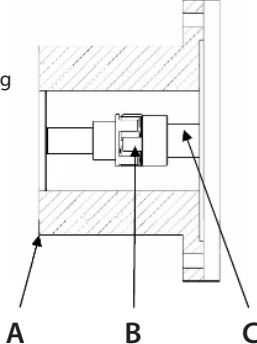


Table of contents

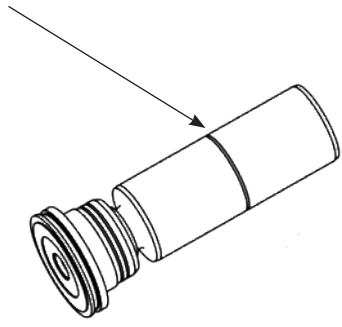
	Trouble shooting fish bone chart63
2.	Reduced flow/reduced pressure65
3.	High torque on electric motor66
6.1	Valve plate69
6.2	Port plate70
6.3	Swash plate70

Trouble shooting fish bone chart



Cause	Remedy	Comments
1.1 Dry running (no water supply to the pump)	If no water comes out of the pump: 1.1.1 Check that inlet valve is open. 1.1.2 Check that booster pump is running.	Mount a low pressure switch in front of the pump and check its set point/ function. The low pressure switch ensures that the pump does not start until the inlet pressure has reached minimum inlet pressure (see User manual).
1.2 Pump reversing (electric motor is running the wrong direction, i.e. counter-clockwise)	1.2.1 Change the phase on the electric motor to make it run clockwise. WARNING: - The pump must not run without water for more than a few seconds. - If the pump takes in water from the high-pressure outlet line, it builds up pressure in pump housing and will eventually break down.	Rotation direction for the APP, APP S or APP S 674 pump is shown by an arrow on the label on the pump. 
1.3 No rotation of electric motor	1.3.1 Check that main switch is switched on. 1.3.2 Check the electricity at the facility. 1.3.3 Ensure that motor relay is switched on. 1.3.4 Ensure that fuse is not blown. 1.3.5 Ensure that booster pump is started. 1.3.6 Check that the monitor switches are working correctly. 1.3.7 Disconnect pump from electric motor and check that the motor is capable of running with no load.	If motor-type relay or the electrical fuse is blown, check that electric motor is sized correctly.
1.4 No rotation of pump	1.4.1 Ensure that coupling between electric motor and pump is connected. 1.4.2 Check if coupling is damaged. 1.4.3 Check that electric motor is sized correctly. 1.4.4 Check that the electrical installation is correctly sized. 1.4.5 Contact Danfoss Sales office for guidelines in how to troubleshoot internal pump parts.	
1.5 Axial load on pump shaft (may cause high internal leakage) Only applying to APP 0.6 to APP 3.5 and APP 21 to APP 26 only. Also applying to APP S and APP S 674 pumps.	1.5.1 Ensure that the air gap between the two coupling parts is min 5 mm. It should always be possible to move the plastic part on the coupling at least 3 mm.	To ensure easy mounting of the flexible coupling without using tools, the tolerances must be dimensioned accordingly. WARNING: Any axial and/or radial loads on the shaft must be avoided. Any axial or radial load will cause breakdown. A - Bell housing B - Flexible coupling C - Motor shaft 
1.6 Pump damage (the internal parts may be damaged)	1.6.1 Contact Danfoss sales office for guidelines in how to troubleshoot internal pump parts.	Instructions on internal elements – are available on hpp.danfoss.com .

2. Reduced flow/reduced pressure

Cause	Remedy	Comments
<p>2.1 Wear on pump Large internal leakage due to:</p>	<p>2.1.1 Dismantle the pump.</p> <p>2.1.2 Check valve plate. Valve plate has marks/scratches on the surface facing the port plate. Minor wear on valve plate can cause large internal leakage. See Index 6.1.</p> <p>2.1.3 Check port plate. Port plate has marks/scratches on the surface facing the valve plate. Minor wear on port plate can cause large internal leakage. See Index 6.2.</p> <p>2.1.4 Check cylinder barrel. Liners in cylinder barrel may be scratched or worn. Insert a piston in the liner and check the fit. If there is any space (clearance) between liner and piston, liner or piston is worn.</p> <p>2.1.5 Pre-treatment Analyse fluid for content of particles. - Check that filters are OK and working correctly.</p> <p>2.1.6 Main filtration Check that the correct filter type is used (particles in fluid must not exceed 10 µm). Danfoss High Pressure Pumps supplies filters, please contact the sales office.</p> <p>2.1.7 Fluid type The APP, APP S and APP S 674 pumps are designed for seawater operation; for any other fluid, please contact Danfoss High Pressure Pumps sales office for further help.</p> <p>2.1.8 High fluid temperature If fluid temperature is above 50 °C (122 ° F), stop the pump immediately.</p> <p>- Check internal parts (see above).</p>	<p>Typical signs of wear: Polished surface all over the swash plate. Normally, only half of the swash plate = the pressure side is polished. See index 6.3.</p> <p>If the ring is missing, the piston is very worn.</p>  <p>The filters can be bypassed, even if they are correctly mounted. Some filters can create channelling where particles can pass through the filter in tunnels. String wounded filters are typically channelling filters. A string wounded filter may have a filtration efficiency of only 50%, which will cause internal wear and must always be followed by a main filter.</p> <p>Insufficient filtration means that too many or too large hard particles can pass the main filter because it is damaged, bypassed or simply too poor. Filtration efficiency must be 99.98% (Beta = 5000) at 10 µm to prevent abnormal wear of the pump.</p> <p>Temperature > 50 °C (122 ° F) will cause wear on internal pump parts. Mount a temperature switch and check its set point / function. The temperature switch will ensure that the pump stops at fluid temperatures > 50 °C (122 ° F).</p>
<p>2.2 Low inlet pressure</p>	<p>2.2.1 Check that booster pump supplies the right pressure/flow.</p> <p>2.2.2 Check if filters require replacement.</p>	<p>If the pressure drop across the filters is too high, the booster pump does not deliver sufficient flow/pressure. No pressure or low pressure results in cavitation and insufficient internal lubrication causing wear on internal pump parts.</p> <p>Mount a low-pressure switch in front of the pump and check its set point/ function. The low-pressure switch ensures that the pump does not start until the inlet pressure has reached 1 bar.</p>
<p>2.3 Rotation speed (rpm)</p>	<p>2.3.1 If VFD-operated, check frequency.</p> <p>2.3.2 Check that rotation speed of the electric motor is as stated on name plate on electric motor. Check that the motor rotor winding is not damaged.</p>	<p>Speeds below min. limit (see User manual) result in insufficient internal lubrication causing wear on the internal pump parts.</p>


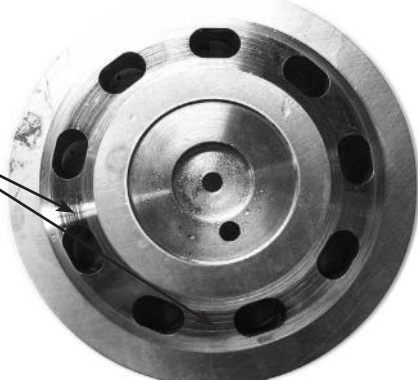
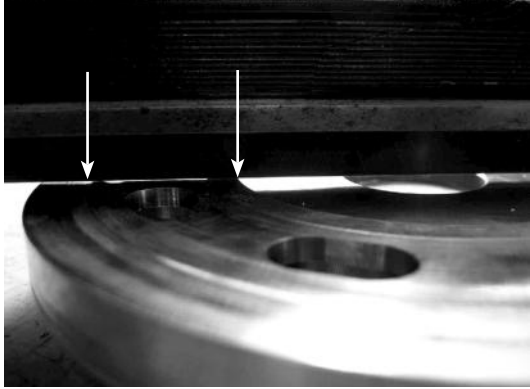
3. High torque on electric motor

Cause	Remedy	Comments
3.1 Too high outlet pressure from pump	3.1.1 Check fluid salinity. 3.1.2 Check temperature. 3.1.3 Check pressure drop across RO membrane.	Pump conditions may change (more salt, lower water temperature or scaling of RO membrane) causing higher pressure, resulting in higher motor torque.
3.2 Pump starts against pressure	3.2.1 Check that electric motor is correctly sized. 3.2.2 Check internal parts (see item 2.1). 3.2.3 Systems with more than one electric motor installed: Start motors simultaneously.	Pumps run in parallel with cascade start, may switch off the motor relay due to too high torque caused by high outlet pressure.
3.3 Constant torque	3.3.1 Please contact Danfoss High Pressure Pumps sales office.	If the electric motor is too small for the APP, APP S or APP S 674 pump, it cannot provide sufficient torque.
3.4 Water pump damage	3.4.1 Dismantle pump and check for wear.	Too heavy damage in the pump will increase friction causing a high torque (see item 6, Typical signs of wear).

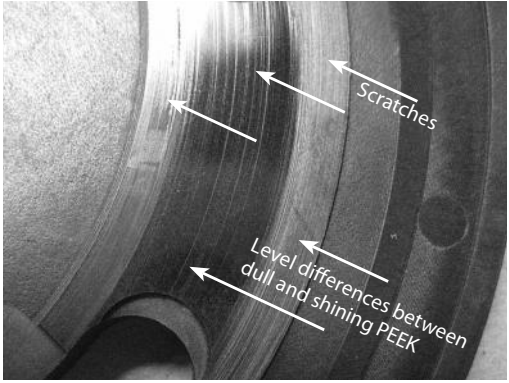
Cause	Remedy	Comments
4.1 Air in fluid	4.1.1 Ensure that the entire inlet line is bled before starting up the system. 4.1.2 Ensure that air cannot enter into the inlet line.	Small air bubbles will accumulate and create large bubbles causing internal cavitation and thus making the pump very noisy. WARNING: The pump can only run few minutes with air in the fluid without being damaged.
4.2 Bleeding conditions of pump	4.2.1 Follow the instructions "Initial start-up" supplied with the new pump. 4.2.2 Ensure that the pump is completely bled before start-up.	The pump and the inlet line must be completely bled before start-up, otherwise the pump will cavitate and make high noise. WARNING: The pump can only run few minutes with air in the fluid without being damaged.
4.3 Min/max nominal inlet pressure	4.3.1 Ensure that inlet pressure is within the limits specified in the User manual. 4.3.2 Check the pump for internal damage.	Too high inlet pressure causes too high pressure inside the pump damaging the pistons and eventually the pump. Inlet pressure below min. limit causes cavitation and insufficient internal lubrication resulting in wear on internal pump parts. Mount a low-pressure switch in front of the pump and check its set point/ function. The low-pressure switch will ensure that the pump does not start until the min. inlet pressure has been reached.
4.4 Pump reversing	4.4.1 Dismantle pump and check if anything is broken or worn (See "1. No flow", item 1.2 Pump reversing"). WARNING: The pump must not run without water for more than a few seconds. If the pump takes in water from the high-pressure outlet line, it builds up pressure and will eventually be damaged.	If pump rotates in wrong direction, it will take in water from the high-pressure outlet line. Pressure will be built up inside the pump and it will eventually be damaged.
4.5 High rotation speed (rpm)	4.5.1 If electric motor rpm is too high, dismantle pump and check for damage. 4.5.2 If the rpm is within the specified range of the pump data sheet and abnormal noise remains, dismantle pump and check for damage.	Higher rpm than specified in the pump data sheet results in wear of the pistons, i.e. pistons may be damaged. High rpm will also increase pressure pulsations from the pump, and the noise level will increase. If rpm is changed, noise frequency will also change.
4.6 Outlet pressure	4.6.1 If outlet pressure is too low, check set point of outlet pressure valve. 4.6.2 If outlet pressure is lower than mentioned in the pump data sheet, please contact Danfoss High Pressure Pumps technical support. 4.6.3 If outlet pressure has exceeded its maximum, check set point of outlet pressure valve. 4.6.4 Check internal parts for wear/damage.	At too low outlet pressure, the pump will create higher pressure pulsations and thus make noise. Too low pressure also causes insufficient internal lubrication and wear on internal parts. Pump may eventually be damaged. Too high outlet pressure may damage the pump.
4.7 Soft start/stop	4.7.1 Check if noise is normal when the pump is running at operation speed. 4.7.2 If noise is abnormal at operation speed, check internal parts (see above).	Noise frequency changes during soft start-up/ stop.

Cause	Remedy	Comments
5.1 Inlet/outlet connections (hoses/pipes)	<p>5.1.1 Use flexible hoses at inlet/outlet connections. Danfoss can provide flexible hoses. Please contact Danfoss High Pressure Pumps sales office for further information.</p> <p>5.1.2 Mount the connections to the frame by a vibration dampener mounting plate.</p>	Non-flexible connections mounted directly on the frame will cause even small pressure pulsations from pump and create vibrations in the system/plant.
5.2 Length/dimension of inlet/outlet line	5.2.1 Increase pipe diameter and/or reduce the number of bends.	Too small pipes or too many bends may create too fast flow/turbulence through the pipes and thus increase the noise level.
5.3 Hose stiffness	5.3.1 Use a more flexible hose. Danfoss can provide flexible hoses. Please contact Danfoss High Pressure Pumps sales office for further information.	Too stiff hoses cannot dampen the small pressure pulsations from the pump, and subsequently vibrations occur in the system/plant.
5.4 Hoses/pipes mounted directly on frame	5.4.1 Mount the connections to the frame by a vibration dampener mounting plate.	If the hoses are mounted directly on the frame, the small pressure pulsations from the pump can be transferred to the frame and the rest of the system/plant.
5.5 Vibration dampener under the electric motor	5.5.1 Mount a vibration dampener below the motor/pump.	When no dampener is installed below the electric motor, vibrations from the motor and pump may be transferred to the frame and the rest of the system/plant.

6.1 Valve plate

<p>Picture 1</p> 	<p>A normally worn valve plate has no marks/scratches but only a slightly polished surface.</p> <p>No scratches or marks should be felt. The surface must be flat and level.</p>
<p>Picture 2</p> <p>Scratches</p> 	<p>A worn valve plate has scratches, and/or a polished surface. Even small scratches will give a loss of flow.</p>
<p>Picture 3</p> 	<p>A good way to identify a worn valve plate is to hold a straight knife edge over the valve plate. When holding it up to the light, it will be possible to see any space between the knife edge and the valve plate. See picture 3.</p> <p>If any light can be seen between the two arrows on the picture, the valve plate is worn.</p> <p>If any scratches or marks can be felt by running a fingernail over the surface, the valve plate is worn.</p> <p>The valve plate on picture 3 is highly damaged.</p>

6.2 Port plate

<p>Picture 1</p> 	<p>If the port plate has scratches, level differences or both between the arrows, the port plate must be replaced.</p> <p>Even small scratches or wear will cause loss of flow.</p> <p>To check: See item 6.1, picture 3.</p>
--	---

6.3 Swash plate

<p>Picture 1</p> 	<p>If the swash plate is polished 360°, it is an indication of insufficient filtration.</p> <p>The surface of the swash plate must be plane and even at same level all over. To check this, please see item 6.1, picture 3.</p> <p>If the surface has any marks/scratches, it is worn/damaged and a new one is required.</p> <p>Please contact Danfoss High Pressure Pumps sales office for further information.</p>
---	--

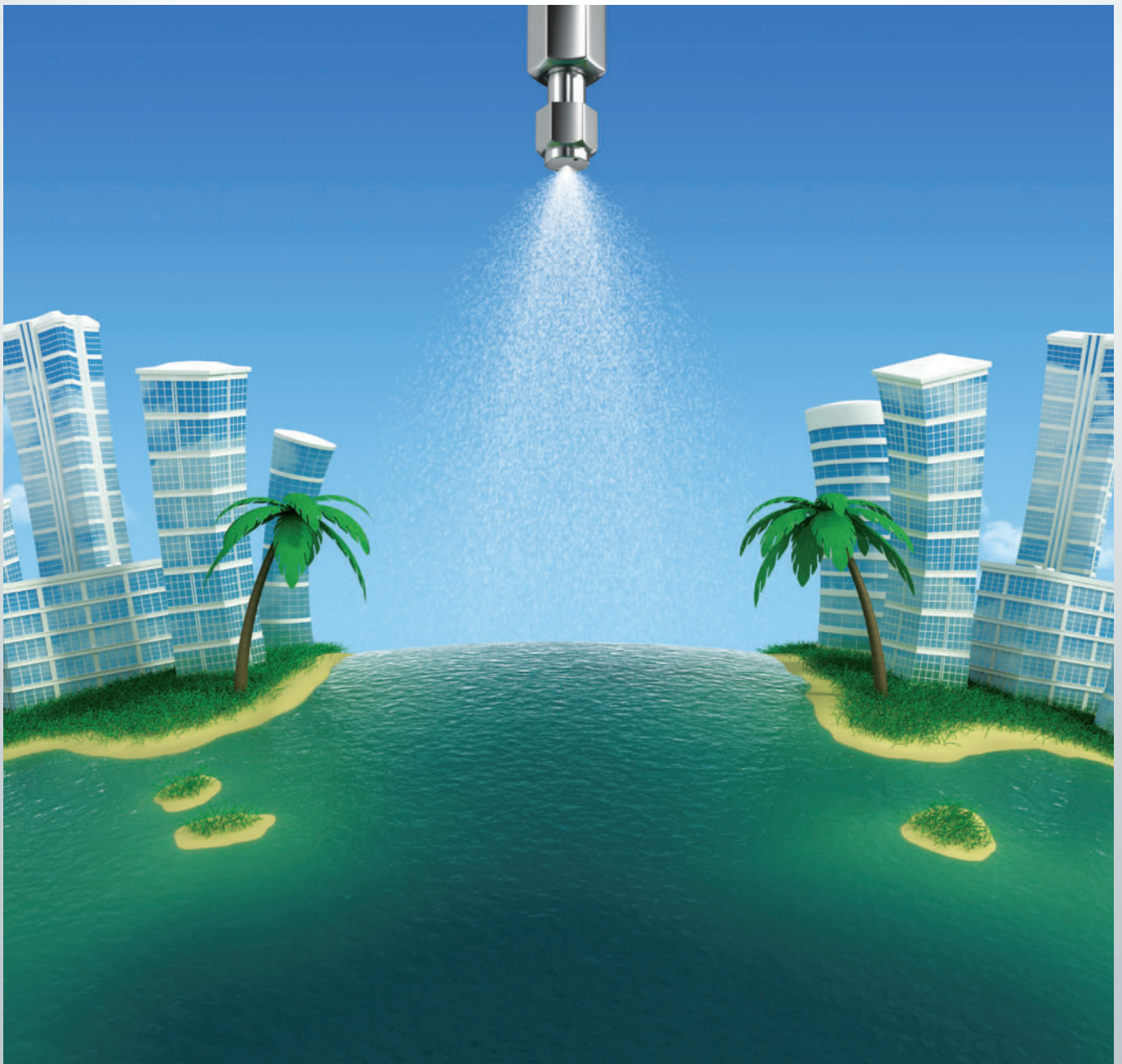
Danfoss A/S
High Pressure Pumps
DK-6430 Nordborg
Denmark

ENGINEERING
TOMORROW

Danfoss

Right and Wrong

Trouble shooting guide for
water hydraulic systems



Design

1. Choice of material

- Rubber
- Plastic
- Stainless steel

Always use system components made of corrosion proof materials

- Iron
- Copper
- Brass
- Aluminium

Non-corrosion proof materials may cause damage

2. Choice of filter

< 10 µm abs.

Install a 10 micron absolute filter with pressure switch

> 10 µm

Return filter with bypass valve and poorer filterability than 10 µm will damage the system

3. Filter location

Locate the return filter in the return line immediately before the tank

Placing the return filter upstream of the final load may damage the pump

4. Pump location

Pump always to be placed below water surface level

Pump location above water surface level will cause damage

5. Suction conditions

System to be dimensioned to provide a suction pressure of the pump inlet of max. 0.1 bar vacuum

Poor suction conditions will cause malfunction and damage the pump

6. Pressure Relief valve

Pressure relief valve to be mounted vertically or with vertical outlet and connected to return hose or tank

Coupling the pressure relief valve outlet directly to the pump inlet may damage the pump

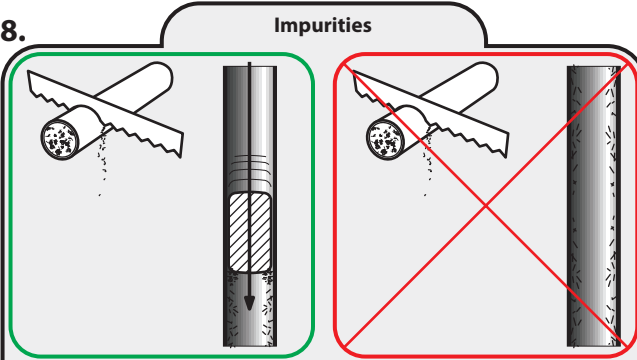
7. Water supply

System to be filled via filter

Filling system with unfiltered water causes damage

Installation

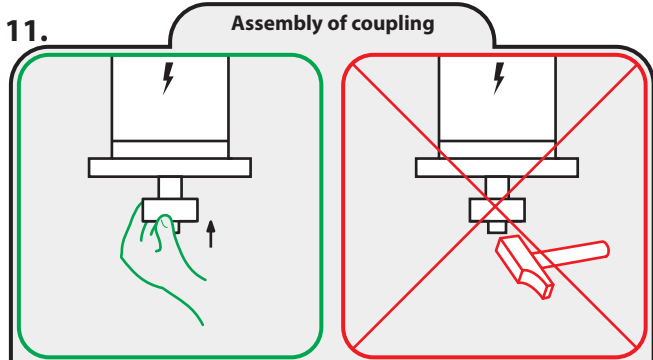
8. Impurities



Prior to installation, burrs and chips and other impurities must be removed from pipes and hoses, eg with a felt plug

Chips or other impurities in the system may cause damage

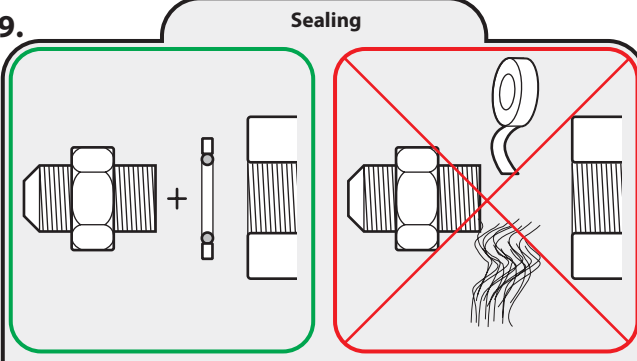
11. Assembly of coupling



The coupling must be easy and simple to assemble (see product instruction)

Never use force when assembling the coupling parts, as this will damage the motor/pump

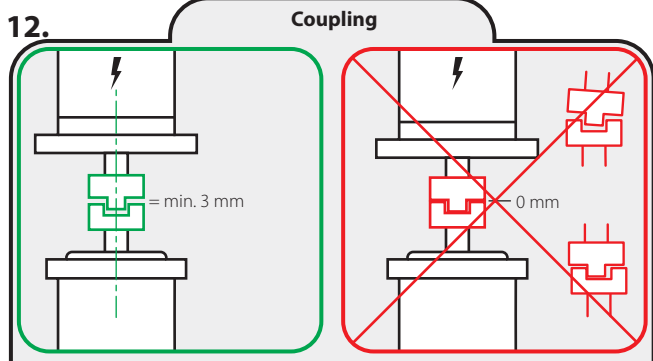
9. Sealing



Fittings in screwed components to be sealed with O-rings or bonded seals

Using teflon tape or packing yarn in joints may cause damage

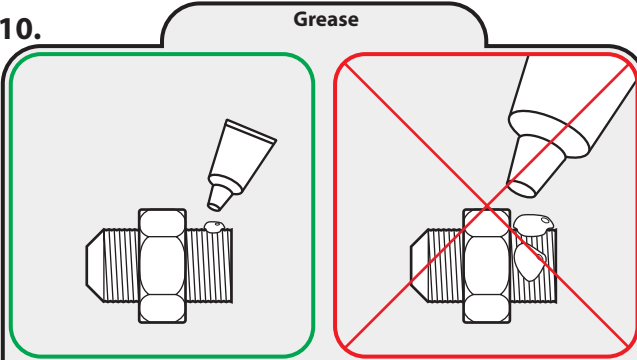
12. Coupling



Ensure always to have 3 mm distance between coupling flanges

Insufficient distance and/or misalignment between the coupling flanges will damage the pump

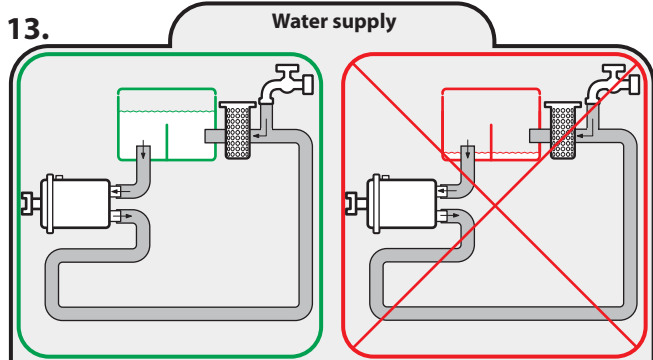
10. Grease



Correctly limited quantities of grease prevent seizing

Too much grease may develop biofilm causing operational failures

13. Water supply



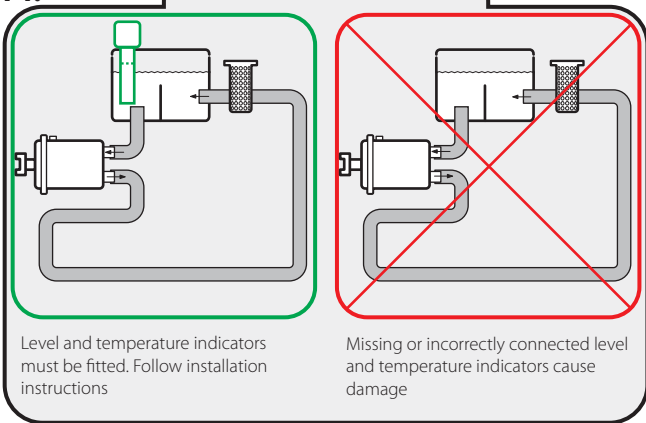
Fill system with water before starting to ensure lubrication and cooling

Starting without water will cause damage

Wiring

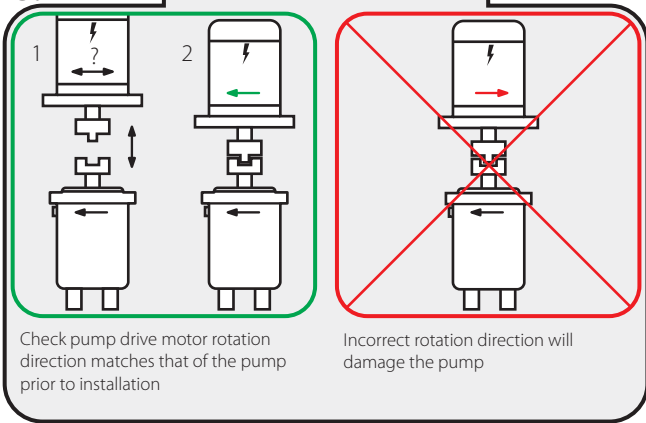
14.

Level indicator



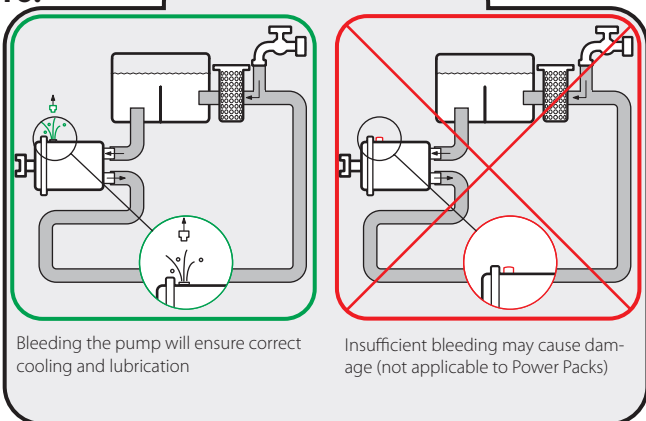
15.

Rotation direction



16.

Bleeding



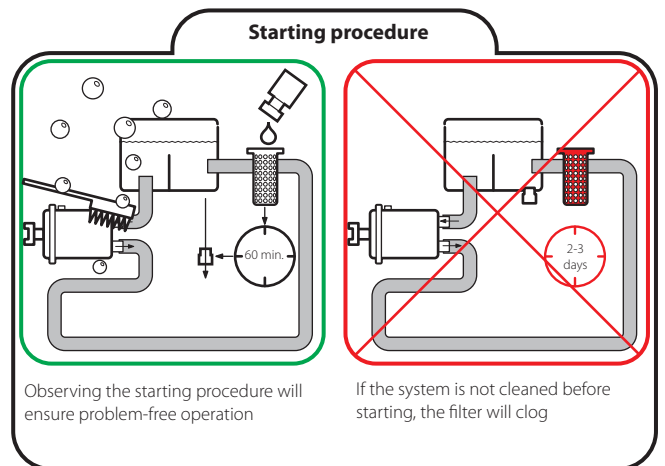
Starting procedure

Cleaning procedure

1. Fill cold water into the system via the return filter and bleed the pump (Power Packs PPH 4 - 6.3 - 10 and 12.5 are self-bleeding)
2. Start and bleed the system -without pressure by opening the bypass valve
3. Add the cleaning agent to give 3% agent/water solution
4. Run the system for 60 min. and activate all components as often as possible to ensure effective flushing with the cleaning agent
5. Empty the system of the cleaning agent solution

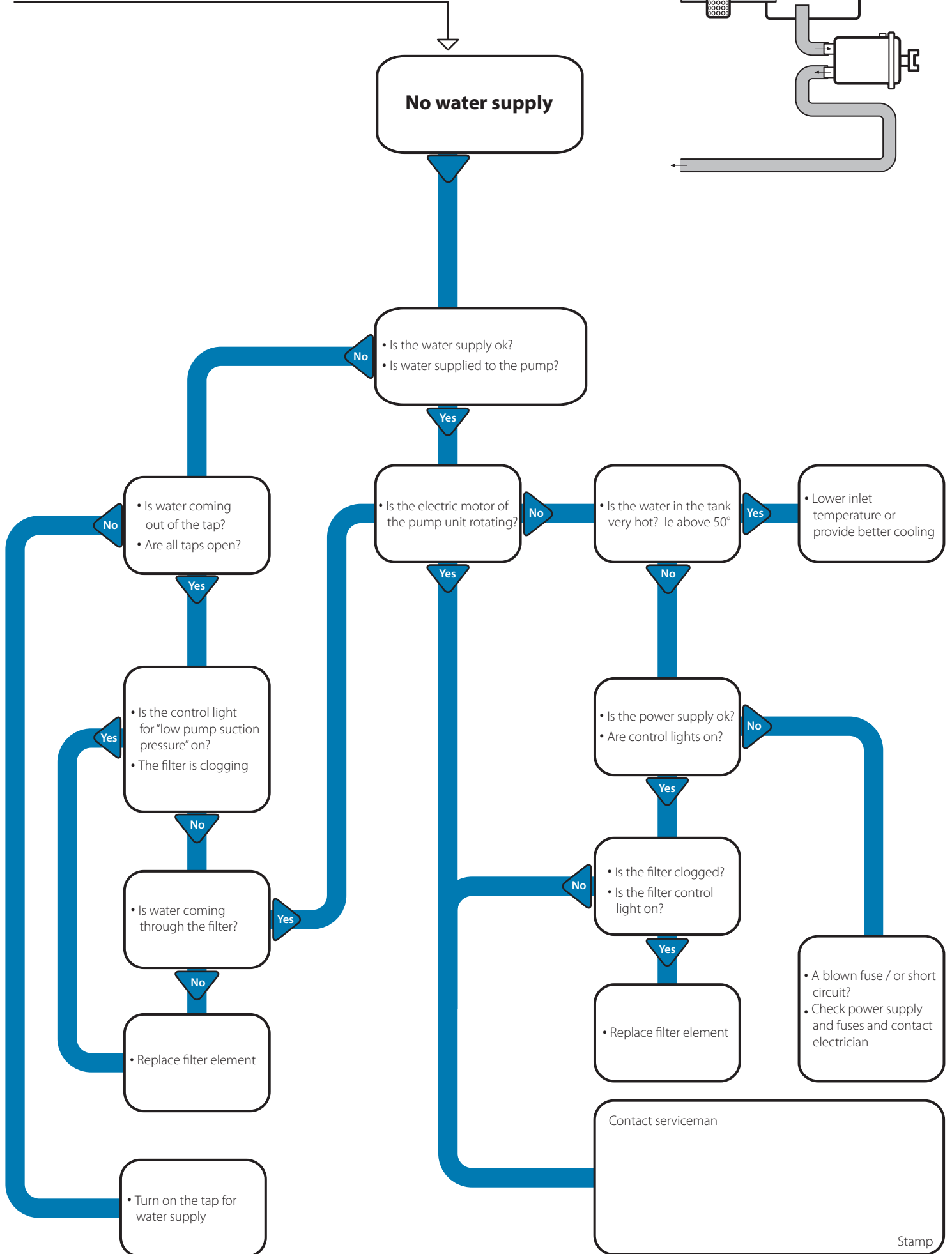
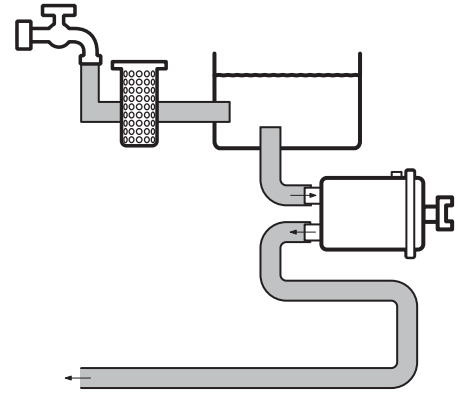
Flushing procedure

6. Fill cold water through the return filter and bleed the pump (Power Packs PPH 4 - 6.3 - 10 and 12.5 are self-bleeding)
7. Run the system for 30 min. and activate all components as often as possible
8. Empty the system of the water
9. Alternatively the system may be flushed by running the unit without the return hose while continuously filling up water. The flushing should continue until there is no trace of cleaning agent in the return water
10. Change the return filter element, fill cold water through the return filter and bleed the pump during start up
11. The system is now ready for operation



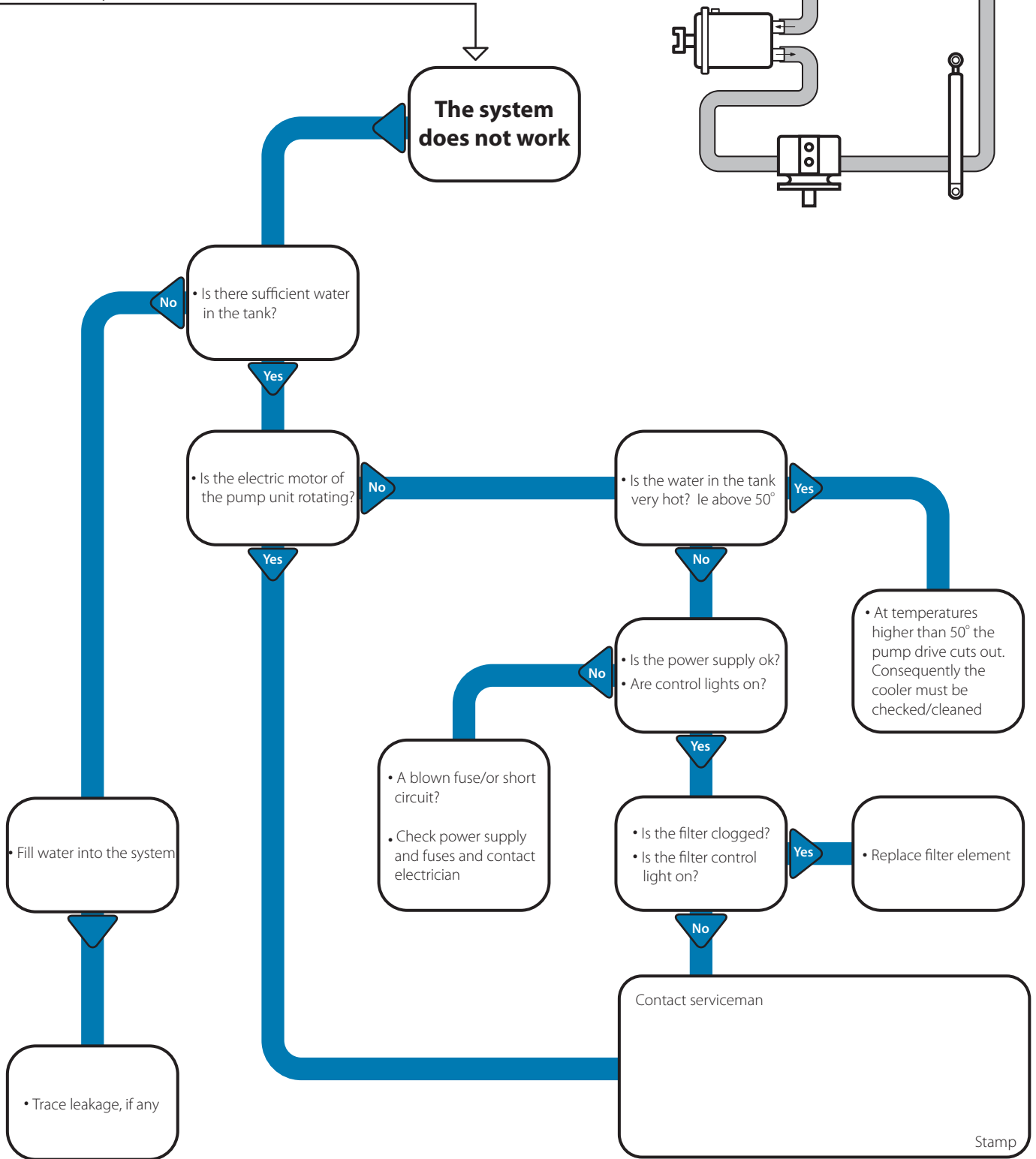
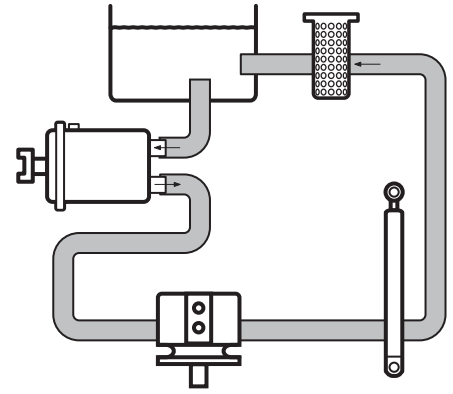
Trouble shooting

Open ended water systems



Trouble shooting

Closed water systems



Danfoss A/S

High Pressure Pumps • danfoss.com • +45 7488 2222 • highpressurepumps@danfoss.com

Any information, including, but not limited to information on selection of product, its application or use, product design, weight, dimensions, capacity or any other technical data in product manuals, catalogues descriptions, advertisements, etc. and whether made available in writing, orally, electronically, online or via download, shall be considered informative, and is only binding if and to the extent, explicit reference is made in a quotation or order confirmation. Danfoss cannot accept any responsibility for possible errors in catalogues, brochures, videos and other material. Danfoss reserves the right to alter its products without notice. This also applies to products ordered but not delivered provided that such alterations can be made without changes to form, fit or function of the product.

All trademarks in this material are property of Danfoss A/S or Danfoss group companies. Danfoss and the Danfoss logo are trademarks of Danfoss A/S. All rights reserved.